

**TOWN OF VALLEYVIEW  
MUNICIPAL ENGINEERING  
SERVICING STANDARDS**



March 1998  
D414-001-00-02

## TABLE OF CONTENTS

### INTRODUCTION      ENGINEERING DESIGN APPROVAL PROCESS

#### A      SUBMISSION STANDARDS

##### A1      DESIGN DRAWINGS

A1.1      General

##### A2      REQUIRED ENGINEERING DRAWINGS

A2.1      Cover Sheet

A2.2      Index Plan

A2.3      Legal, Easement and Land Use Plan

A2.4      Road, Sidewalk and Storm Sewer Plan

A2.5      Lot Grading Plan

A2.6      Sanitary Sewer and Water Main Plan

A2.7      Plan/Profile and Standard Detail Drawings

#### B      ROADS

##### B1      GEOMETRIC DESIGN STANDARDS

B1.1      General

B1.2      Vertical Alignment

B1.3      Horizontal Alignment

B1.4      Survey Control Markers and Legal Pins

##### B2      GENERAL REQUIREMENTS

B2.1      Pavement Structure

B2.2      Sidewalks and Walkways

B2.3      Concrete Curb and Gutter

B2.4      Driveways

B2.5      Berming, Fencing and Landscaping

B2.6      Cul-de-Sacs

B2.7      Intersections

B2.8      Laneways

B2.9      Utility Trenches

B2.10      Street Signs

#### C      SANITARY SEWER SYSTEM

##### C1      DESIGN FACTORS

C1.1      General

C1.2      Average Flows

C1.3      Peaking Factor

C1.4      Velocities

C1.5      Manning's "n" Value

C1.6      Weeping Tiles

C1.7      Infiltration Allowance

- C2 MATERIALS
  - C2.1 Sewer Mains
  - C2.2 Manholes
- C3 INSTALLATION
  - C3.1 Sewer Mains
  - C3.2 Manholes
  - C3.3 Culverts
  - C3.4 Curved Sewers
  - C3.5 Compaction in Trench
  - C3.6 Inspection and Testing
  - C3.7 Service Connections

D WATER DISTRIBUTION SYSTEM

- D1 NETWORK ANALYSIS
- D2 MATERIALS
  - D2.1 Water Mains
  - D2.2 Hydrants
  - D2.3 Valves
  - D2.4 Service Connections
- D3 INSTALLATION
  - D3.1 Water Mains
  - D3.2 Compaction in Trench
  - D3.3 Inspection and Testing
  - D3.4 Hydrants
  - D3.5 Valves
  - D3.6 Water Service Connections

E STORM DRAINAGE SYSTEM

- E1 MINOR SYSTEM
  - E1.1 Design Criteria
- E2 MATERIALS
  - E2.1 Sewer Mains and Leads
  - E2.2 Catch Basins
  - E2.3 Manholes
- E3 INSTALLATION
  - E3.1 Sewer Mains
  - E3.2 Catch Basin Leads
  - E3.3 Catch Basins
  - E3.4 Manholes
  - E3.5 Compaction in Trench
  - E3.6 Inspection and Testing

E4 MAJOR SYSTEM  
E4.1 General

F PARK DEVELOPMENT

F1.1 Definitions  
F1.2 Development

G GAS, POWER AND TELEPHONE SERVICES

G1.1 Gas, Power and Telephone  
G1.2 Street Lighting

APPENDIX I - PLAN STANDARDS

1 DESIGN DRAWINGS

1.1 Drawing Techniques  
1.2 Scales  
1.3 Geodetic Datum  
1.4 Plan Size

2 PLAN AND PROFILE DRAWINGS

2.1 General  
2.2 Road and Right-of-Way Information  
2.3 Sanitary and Storm Sewer Information  
2.4 Water Distribution Information  
2.5 Standard Detail Drawings

3 AS-BUILT DRAWINGS

3.1 General  
3.2 Water and Sanitary Service Connection Information  
3.3 Standard Details

APPENDIX II - SAFETY PROGRAM GUIDELINES

APPENDIX III - STANDARD DRAWING DETAILS

## GENERAL

The standards outlined herein are intended to be minimum standards. Higher standards shall be applied when warranted by good engineering and construction practices. The developer shall be responsible for developing the subdivision in accordance with standards acceptable to the Town and conforming to good engineering and construction practices.

The developer shall notify the Town in writing forty-eight (48) hours in advance of starting construction. Written notice shall also be provided forty-eight (48) hours in advance of street closures or utility shutdowns. The Town shall also be notified when streets are reopened and utilities back in service.

The Town requires a safe work permit to be completed and approved prior to any excavation in a public right-of-way or tie into a public utility. Application shall be made for a safe work permit forty-eight (48) hours prior to planned excavation. Town also has to see copy of Authorization from Alberta Environment Standard Municipal Branch.

A carbon copy of all test results to be submitted to the Town Engineer prior to applying for completion certificate.

INTRODUCTION      ENGINEERING DESIGN APPROVAL PROCESS

DETAILED ENGINEERING DESIGN SUBMISSION

.1      General

- .1      The standards outlined herein are intended to be minimum standards. Higher standards shall be applied when warranted by good engineering and construction practices. The Developer shall be responsible for developing the subdivision in accordance with standards acceptable to the Town and conforming to good engineering practices.

.2      Submission Requirements

- .1      The following will be submitted as part of the application for detailed design approval:
- .1      A covering letter indicating the subject and purpose of the application, an estimated construction starting date and the proposed schedule for site meetings.
  - .2      Three complete sets of the engineering drawings. Sets which do not contain the required drawings as outlined in Section A2 will not be accepted for processing.
  - .3      Three sets of specifications, complete with tender form.
  - .4      Three copies of the Geotechnical Report, including an analysis of the ground water table.
  - .5      Two copies of the engineering calculations for each of the storm and sanitary sewer systems. Where requested by the Town, the results of a detailed analysis of the water supply system will be included with the submission.
  - .6      An estimated construction schedule outlining the sequence of construction to be followed and applicable critical dates.
  - .7      Additional technical detail required to satisfy the conditions of subdivision approval.

.3      Responsibilities

- .1      The Developer will be responsible for providing all detailed engineering requirements as outlined in these Standards. Additional information may be requested by the Town as deemed necessary.
- .2      The Developer will arrange and negotiate any and all easements across private lands, crossings of utilities lines and other similar agreements which may be needed with land owners in the area.
- .3      The Town will on request supply all available information on existing utilities including available capacities, locations, restrictions and limitations. However the applicant must confirm the information provided, in the field, as the Town does not guarantee the accuracy or completeness of any information provided.

*Town owned*

- .4 The Developer will apply for all required permits from Provincial Government Departments. The Developer will supply all necessary documentation, plans and specifications to be forwarded with each application.
- .5 The Developer will be required to have a public meeting prior to construction with the area residents , utility personnel and Town staff in attendance.
- .6 The Developer shall develop, maintain and supervise for the duration of the work a comprehensive safety program that will effectively incorporate and implement all required safety precautions. The program shall, as a minimum, respond fully to the requirements of all applicable laws, ordinances, rules, regulations and orders and general construction practices for the safety of persons or property, including without limitation any general safety rules and regulations of the Town and any Workers' Compensation or Occupational Health and Safety legislation or regulations that may be applicable (e.g. WHMIS). The Developer shall provide a copy of the safety program to the Town prior to the commencement of construction. The Town requires a safe work permit to be completed and approved prior to any excavation in a public right-of-way or tie into a public utility. Application shall be made for a safe work permit forty-eight (48) hours prior to planned excavation.
- .7 The Developer shall notify the Town in writing forty-eight (48) hours in advance of starting construction. Written notice shall also be provided forty-eight (48) hours in advance of street closures or utility shutdowns. The Town shall also be notified when streets are reopened and utilities back in service.
- .8 The Final Acceptance Certificate for roads shall be issued, subject to all deficiencies being rectified, two years after the issuance of the Construction Completion Certificate for roads or one year after the issuance of the Final Acceptance Certificate for underground improvements, whichever occurs later. The Final Acceptance Certificate for utilities shall be issued, subject to all deficiencies being rectified, one year after the issuance of the Construction Completion Certificate for utilities. Copies of all material testing results shall be submitted to the Town prior to applying for Construction Completion Certificate.

**A     SUBMISSION STANDARDS**

**A1    DESIGN DRAWINGS**

**A1.1   General**

- .1     All detailed engineering plans submitted for review and approval must comply with the specifications herein stated.
- .2     Refer to Appendix I for detailed information on drawing requirements.

**A2    REQUIRED ENGINEERING DRAWINGS**

The drawings identified shall clearly highlight the detail as indicated.

**A2.1   Cover Sheet**

- .1     This shall show the name of the subdivision, stage of development and names of the Developer, planner and consulting engineer. In addition the Town of Valleyview shall be identified.

**A2.2   Index Plan**

- .1     This plan shall be prepared on a scale of 1:1000 or a reduction thereof to fit the standard size A-1 sheet (594 mm x 841 mm) and shall indicate that portion of the street which relates to a particular plan/profile sheet.
- .2     This sheet shall list each drawing included in that particular set of drawings. Each drawing name is to be listed sequentially along with its corresponding drawing number. Also included on this plan shall be a key plan in sufficient detail to show the location of the project with respect to major roads and built up centres.

**A2.3   Legal, Easement and Land Use Plan**

- .1     This plan shall indicate proposed land uses in the project along with existing and/or proposed land use on adjacent properties.
- .2     All legal and easement information shall be shown on this plan.
- .3     PUL widths shall be a minimum of 4.0 m for a single service and 6.0 m for a dual service. A 1.0 m easement is required on each side of a PUL. A single service centred in a 6.0 m PUL will not require additional easements.

**A2.4   Road, Sidewalk and Storm Sewer Plan**

- .1     This plan shall indicate all walks, lanes, road and right-of-way widths and alignments, catch basin locations, the storm sewer system, the direction of overland flow on the streets and local drainage areas which contribute to the storm sewer system.



#### A2.5 Lot Grading Plan

- .1 Lots shall be designed to drain from back to front except where the Developer can satisfy the Town that back to front drainage is not technically feasible. If an alternate system is required it must be designed so that surface water crosses the fewest lots possible in its path to the street. No more than 2 lots shall be crossed. In extreme cases the Town may permit more than 2 lots to be crossed provided drainage easements are established. Minimum and maximum slopes on landscaped areas to be 2% and 10% respectively. An initial minimum grade of 10% over a distance of 1.5 m is to be provided around all buildings. Driveway slopes must be no less than 2% and no greater than 8%.
- .2 The plan shall highlight the following:
  - .1 The proposed finished lot corners, mid lot and house elevations, the direction of flow of surface drainage on the lot, proposed curb alignments, all required rear and side yard swales and sewer connection inverts at the property line.
  - .2 Bench marks used in the construction of the project.
  - .3 Existing contours shown at a 0.5 m intervals.
  - .4 The overland major drainage system including ponding areas and depths resulting from a 1:100 year storm.

#### A2.6 Sanitary Sewer and Water Main Plan

- .1 This plan shall indicate the alignment and locations of mains, size of mains, grade and directions of flow and location of appurtenances.
- .2 Indicate location of sanitary and water services.
- .3 Waterline bacteria sampling locations are to be identified.

#### A2.7 Plan/Profile and Standard Detail Drawings

- .1 The Plan/Profile and Standard Detail Drawings shall be drawn to avoid clutter and promote clarity and legibility.
- .2 Refer to Appendix I for detailed information on drawing requirements.

END OF SECTION A

**B**     **ROADS**

**B1**    **GEOMETRIC DESIGN STANDARDS**

**B1.1**   **General**

- .1     Road classification and designation shall be in accordance with the classification system outlined in the Transportation Association of Canada (TAC) Manual - Geometric Design Standards for Canadian Roads and Streets.
- .2     Individual street classification is to be based on functional use.
- .3     The Developer and the Developer's Consultant are responsible to ensure that the infrastructure is designed and constructed to achieve design life expectations consistent with good design and construction practice.

**B1.2**   **Vertical Alignment**

.1     **Grade**

- .1     The minimum grade shall be 0.5% along all gutters and 0.8% around curb returns.
- .2     The maximum grade shall be 6.0%.
- .3     All roads shall be crowned.

.2     **Vertical Curves**

- .1     All vertical curves shall be designed to meet the minimum requirements as shown in Table B1.

TABLE B1		
Design Speed (km/hr)	K Value	
	Crest (m)	Sag (m)
50	7	6
60	15	10
70	22	15
80	35	20

Where:      $K = L/A$   
               $L =$  Length of Vertical Curve in Metres  
               $A =$  Algebraic Difference in Grade Percent

- .2 The minimum length of a vertical curve shall be 30 m.
- .3 Vertical curves are not required where the algebraic difference of the grades is less than 1.5.

**B1.3 Horizontal Alignment**

**.1 Curves**

- .1 The minimum degree of curvature is dependent on the road classification and its design speed.
- .2 All horizontal curves shall be designed to meet the minimum design requirements as shown in Table B2.

TABLE B2				
Classification	Minimum Radius of Curve (m)	Maximum Tangent Length (m)	Maximum Gradient (%)	Intersection Spacing (m)
Residential Cul-de-sac	90	30	6	60
Local Residential	90	30	6	60
Local Industrial	90	30	6	60
Minor Residential	90	60	6	60
Major Residential	130	60	6	60
Industrial Collector	130	60	6	60
Minor Arterial	450	60	5	400
Major Arterial	500	60	5	400

- NOTES: 1. See TAC B-16 for superelevation requirements on arterials.  
 2. Design speeds are 60 km/h except minor and major arterials which are 70 and 80, respectively.

**B1.4 Survey Control Markers and Legal Pins**

**.1 Existing Control**

- .1 The Developer or their Consultant shall make every effort to protect existing markers.
- .2 Markers which are destroyed or disturbed shall be replaced by the Developer at his sole expense.

**.2 Survey Control Density**

- .1 Additional markers, as required by Alberta Forestry, Lands and Wildlife, Alberta Bureau of Surveys and Mapping Branch, shall be added to the existing network by the Developer to maintain the necessary density for survey control.

.3 Legal Posts

- .1 Front lot legal posts shall be clearly marked with a flexible marker post extending a minimum of 1.0 m above grade at initial posting of the subdivision.
- .2 The Developer shall instruct the legal surveying consultant to replace any missing or disturbed posts as required by the Town. All costs are to be borne by the Developer.

B2 GENERAL REQUIREMENTS

B2.1 Pavement Structure

- .1 The Geotechnical Report for the proposed project shall be submitted to the Town for review as part of the overall submission.
- .2 The Geotechnical Report must include specific recommendations for pavement structure construction based on in situ conditions and projected traffic volume. The stronger of the structure recommended by the Geotechnical Consultant and the structure shown in Table B3 shall be used.
- .3 Table B3 indicates the minimum thicknesses of granular and asphaltic concrete materials required for each street classification. Note that a minimum subgrade preparation of 150 mm is required in every case. The subgrade and base gravel must be compacted to 100% Standard Proctor Density.
- .4 Alternative pavement designs of equivalent strength along with supporting material, may be submitted to the Town for review and approval prior to construction.

Street Classification	Road Structure			
	Hot Mix Asphalt (mm)	Granular Base Course (mm)	Granular Sub-Base (mm)	Subgrade Preparation (mm)
Local Residential	75	100	300	150
Minor Collector	100	150	300	150
Major Collector	150	150	400	150

NOTES: 1. Filter fabric shall be used under the granular sub-base in all cases.

## B2.2 Sidewalks and Walkways

- .1 Separate sidewalks shall be a minimum width of 1.5 m. Separate sidewalks shall be constructed on all major collector roadways and may also be used on local residential streets.
- .2 Sidewalks are required on both sides of all streets except arterials and cul-de-sacs. A sidewalk around a cul-de-sac bulb shall only be required if it shall provide continuity with an existing or proposed walkway through the bulb.
- .3 The requirements for sidewalks in an industrial area shall be reviewed on an as required basis in conjunction with the proposed commercial character of the area, the need for bus routes and other municipal services.
- .4 Paraplegic ramps are to be used at all curbed intersections and shall be constructed monolithically or securely dowelled.
- .5 All sidewalks shall be imprinted with the Contractor's stamp showing company name and year of construction. Frequency of stamps shall be one per residential block or every 200 m whichever is less.
- .6 Sidewalks shall be imprinted with a "CC" to identify all CC locations.
- .7 All concrete structures are to be adequately reinforced. All concrete structures require a minimum compressive strength of concrete at 28 days of 30 MPa. In all, concrete air entrainment by volume shall be a minimum of 6% and a maximum of 8%. The subgrade and base gravel under concrete structures must be compacted to 100% Standard Proctor Density.
- .8 The design of the subdivision should consider pedestrian needs and allow for walkways through cul-de-sacs and other appropriate locations.

## B2.3 Concrete Curb and Gutter

- .1 Concrete curb and gutter shall be constructed on all streets.
- .2 Vertical face curb and gutter is to be used on all major collector and arterial roads. All roads fronting parks, public utility lots, (other than emergency accesses) and walkways shall also require vertical face curb and gutter unless another means of preventing vehicular access onto these public lands is provided.
- .3 Curb returns on residential street intersections shall be constructed with a minimum radius of 10.0 m.
- .4 Curb returns in industrial/commercial areas shall be constructed with a minimum radius of 15.0 m to accommodate truck turning movements.
- .5 Local residential streets will be low profile curb.

- .6 All concrete curbs and monolithic curbs and walks shall be constructed with the same subgrade structure as the adjacent road. The structure is to extend 300 mm beyond the back of curb or walk.

#### B2.4 Driveways

- .1 Residential subdivision lot layout shall be such that driveways shall not access directly onto arterial roadways.
- .2 All driveways shall be constructed to provide a minimum clearance of 1.5 m from any structure including hydrants, light standards, service pedestals, curb cocks and transformers.
- .3 No driveways or any portion thereof shall be permitted to access an abutting road through a curb return area
- .4 For corner lots the driveway zone must be indicated for the street of lesser traffic only.

#### B2.5 Berming, Fencing and Landscaping

- .1 Consistent screen fencing shall be required on all arterial and collector roadways where the lots back onto the roadway. Berming and fencing shall be required to separate residential developments from high volume arterial traffic.
- .2 All berms shall have maximum side slopes of 4:1, a top width of 1.0 m and be topsoiled and sodded/seeded. Berm tops shall be centred on the property line. Where berm design provides for less than 5 m from toe to curb additional land must be dedicated for the right-of-way.
- .3 Fencing proposals are to be reviewed for acceptance by the Town prior to construction. Construction of fencing may not start until an acceptable plan has been provided and written acceptance granted. Fencing along arterial roads and utility lots shall be of a close boarded type and extend to ground level. Fencing along parks, schools and other public open space shall be 1.5 m high chainlink or lower pipe rail variety at the discretion of the Town. All fences shall be constructed on private property approximately 150 mm from the property line.

#### B2.6 Cul-de-Sacs

- .1 The normal maximum length of a cul-de-sac is one hundred and twenty (120) metres from the street curb line to the start of the bulb. Cul-de-sacs in excess of 120 metres and less than 170 metres will require an additional hydrant and water main looping. Where cul-de-sacs in excess of 170 metres are proposed, provision must be made for a 6.0 m wide Public Utility Lot (PUL) for emergency vehicle access and water service looping. Emergency vehicle access PUL's shall be developed to a standard acceptable to the Town.

- .2 Cul-de-sacs with steep grades are to be avoided. If cul-de-sacs cannot be graded to drain towards the intersection then an outlet for the overland flow must be provided by way of a PUL.
- .3 The recommended radius of cul-de-sac bulbs is 14.0 metres to face of curb. The minimum standard is 12.0 metres to face of curb.

#### B2.7 Intersections

- .1 The minimum angle of intersection for two roadways shall be 75 degrees.
- .2 Acceptance of intersection design, driveway locations and fencing shall be subject to review of available sight distances and other safety considerations. Tapering of berms at intersections may be required to provide for the necessary sight distances. Acceptance shall be granted on a case by case basis.
- .3 The Developer shall provide confirmation that sight distances, and horizontal and vertical visibility constraints at the access to arterial roadways meet the applicable stopping sight distances.
- .4 Minimum centre line to centre line spacing of intersections shall be 60 m along local and collector roadways.
- .5 All intersections shall have underground storm sewers and catch basins for the collection of surface drainage. (No road swales)

#### B2.8 Laneways

- .1 All laneways shall be a minimum of 4.0 m in width.
- .2 Laneways shall be paved over their full width with a minimum structure of 75 mm depth of asphalt over 200 mm of an approved granular base.
- .3 An inverted cross-section shall be used for laneway construction.

#### B2.9 Utility Trenches

- .1 In all new subdivisions it shall be the Developer's responsibility to ensure that utility trenches are adequately compacted. Within the road carriage way, 98% Standard Proctor Density shall be required; 95% Standard Proctor Density in all other areas. In existing subdivisions, the utility companies shall be responsible to ensure adequate compaction in utility trenches for any new installations or modification of existing lines.
- .2 The Developer's consultant is to coordinate locations of shallow utility crossings of roadways with the respective utility company. All shallow utilities are to be contained in conduit of appropriate size and number for all roadway crossings.

**B2.10 Street Signs**

- .1 High intensity reflective material is required for the lettering and background for all signage.
- .1 Street name signs at intersections shall consist of white lettering on a blue metal plate. Lettering sizes shall be as follows:
  - 200 mm arterial roadways
  - 150 mm major collector roadways
  - 100 mm minor collector and local roadways.
- .2 100 mm white address numbering on a blue metal plate will be required on all cul-de-sacs in addition to the street name signage.
- .2 Traffic control signage will be required at all intersections.

END OF SECTION B



C SANITARY SEWER SYSTEM

C1 DESIGN FACTORS

C1.1 General

- .1 The sanitary sewerage system shall be of sufficient capacity to carry peak flows plus infiltration. The factors outlined in the following sections shall be used in the design of sanitary sewerage systems.
- .2 The Developer and the Developer's Consultant are responsible to ensure that the infrastructure is designed and constructed to achieve design life expectations consistent with good design and construction practice.

C1.2 Average Flows

- .1 Residential - 450 litres/day/capita
- .2 Commercial/Industrial - 18.0 m<sup>3</sup>/ha./day
- .3 In determining residential flows a minimum of 3.5 persons per household shall be used.

C1.3 Peaking Factor

- .1 The peaking factor shall be calculated on the Harmon Formula. The minimum peaking factor shall be 3.0.
- .2 The peaking factor must reflect the projected population of the subdivision being designed.

C1.4 Velocities

- .1 Minimum flow velocity - 0.60 m/s
- .2 Maximum flow velocity - 3.0 m/s

C1.5 Mannings "n" Value

- .1 Pipe sizing shall be determined by utilizing the Manning's Formula using a minimum "n" value of 0.013.
- .2 The minimum grade of the first upstream leg of the sanitary sewer shall not be less than 1.00%.

## C1.6 Weeping Tiles

- .1 Weeping tiles and similar appurtenances shall not be permitted to discharge into sanitary sewers. Weeping tiles may be connected to sumps with pumped discharge directly to ground surface (splash pads are required to insure positive drainage away from the house for a distance of 1.5 m). Sump pump discharge lines to the ground surface shall be limited to 1.5 m from the face of the building at the point of discharge. Connections to storm sewer shall be permitted only if the storm sewer system is designed to handle weeping tile flow and only after the Town has reviewed and accepted the design. Other alternatives may be submitted to the Town for acceptance.
- .2 The geotechnical report shall address the problems of weeping tile flow associated with a high groundwater table or other subsurface anomalies.

## C1.7 Infiltration Allowance

- .1 The design of the sanitary sewer system must provide for peak extraneous flow. A minimum allowance of 20,000 litres/day per gross hectare must be incorporated into the design.

## C2 MATERIALS

### C2.1 Sewer Mains

- .1 The minimum pipe size shall be 200 mm inside diameter.
- .2 Pipe for sewer mains shall conform to one of the following:

<u>Material</u>	<u>Class</u>
Concrete Pipe (Sulfate Resistant Cement)	ASTM C14 or ASTM C76
PVC Pipe	ASTM D3034 Minimum Class SDR35
PVC Pipe Fittings	To comply with the Alberta Labour Plumbing and Gas Safety Standards for fabricated PVC DWV fittings 200 mm through 600 mm minimum Class SDR35

## C2.2 Manholes

- .1 Manhole sections shall be precast reinforced concrete sections conforming to ASTM C478, latest revision thereof.
- .2 All manholes shall be 1200 mm inside diameter.
- .3 Manhole steps shall be standard safety type, hot dipped galvanized iron or aluminum.
- .4 All joints shall be sealed with rubber gaskets and grouted inside and outside.
- .5 Manhole frames and covers shall be Norwood NF 80 cast iron conforming to Class 20 ASTM A48, latest revision thereof.
- .6 Manhole bases shall be precast slabs, concrete poured bases, vaults or precast tees.
- .7 Concrete for manholes and appurtenances shall be sulphate resistant with a maximum slump of 75 mm and minimum 28 day strength of 25 MPa.
- .8 Safety platforms shall be required in all manholes with a depth greater than 6.5 m.

## C3 INSTALLATION

### C3.1 Sewer Mains

- .1 Mains shall be installed to provide a minimum depth of cover to invert of 2.75 m below the final finished surface grade.
- .2 Accepted pipe bedding shall be provided for all mains.
- .3 Minimum gradients on straight runs shall conform to Alberta Environment Recommended Standards for Water Supply and Sewerage, latest edition.

### C3.2 Manholes

- .1 Manholes shall be located at the end of each line, at all changes in pipe size, grade, alignment and at all junctions.
- .2 The maximum distance between manholes shall not exceed 120 m.
- .3 Inverts in manholes shall have a minimum 25 mm drop for straight run sewer manholes. At changes in direction, manholes shall have at least 40 mm fall across the manhole in the direction of flow from inlet to outlet elevation.
- .4 Backfill around manholes shall be compacted with mechanical tampers to a minimum of 98% Standard Proctor Density.

- .5 Internal drops are required for invert grade differences greater than 1.0 m in sanitary sewer manholes.

### C3.3 Culverts

- .1 Culverts shall be new corrugated steel or plastic equivalent manufactured in accordance with CAN3-G401. Steel pipe shall be zinc coated by a hot dip galvanized process and have a minimum thickness of 1.6 m. The corrugated band couplings shall conform to CAN3-G401.
- .2 Minimum culvert size shall be 300 mm diameter and be of sufficient length to accommodate the roadway and turning radius with 3:1 side slopes.
- .3 Backfill shall be completed as stated in Item B2.9 (Utility Trenches).
- .4 Bedding will consist of a minimum of 150 mm layer of compacted granular material and compacted to at least 95% Standard Proctor Density.
- .5 For culverts installed along main water courses, the base shall consist of compacted granular bedding to a minimum depth of 300 mm.
- .6 Water is not allowed to flow through pipes during installation unless approved by the Town.
- .7 All culverts shall be laid so that horizontal seams fall at the sides of the culverts.
- .8 Installation of damaged culverts is not permitted.

### C3.4 Curved Sewers

- .1 Curved sewers shall be permitted with the following restrictions:
  - .1 PVC and concrete pipe shall be placed in accordance with manufacturer's guidelines.
- .2 The curve shall run parallel to the curb or street centre line.
- .3 The minimum grade for sewers on a curve shall be 50% greater than the minimum grade required for a straight run of sewer.
- .4 Manholes shall be located at the beginning and end of each curve and intermediate locations as required.

### C3.5 Compaction in Trench

- .1 Accepted bedding material shall be compacted to a minimum 95% Standard Proctor Density.
- .2 Trench compaction shall be a minimum 98% Standard Proctor Density.
- .3 Backfilling shall be carried out using selected material compacted in 150 mm layers.

### C3.6 Inspection and Testing

- .1 Video camera inspection reports shall be conducted on each sewer line and tapes shall be provided to the Town. Tapes used in the video reports shall be in colour and compatible with VHS viewing equipment.
- .2 Video camera inspection reports shall be conducted on every fourth sewer service line between the main and the inspection chamber and tapes shall be provided to the Town. Should any one service line be deficient, then all service lines shall be inspected by video camera.
- .3 Where deemed necessary by the Town an exfiltration and/or infiltration test shall be conducted. These tests shall not be required if video inspections are done immediately after sewer construction and no deficiencies are observed. Any deficiencies shall be corrected by the contractor and those portions of sewer affected shall be subject to an additional video inspection. Allowable sewer leakages are as follows:

<u>Pipe Material</u>	<u>Leakage Allowance</u>
PVC	Infiltration Test: 5.0 L/day/mm dia/km is allowable with no allowance for external hydrostatic head. The groundwater table is to be above pipe crown at all locations of the test section. Exfiltration Test: 5.0 L/day/mm dia/km is the combined allowable exfiltration from pipe and manholes with hydrostatic head at the high manhole is to be a minimum 0.6 m higher than crown of pipe or groundwater table, whichever is higher. The water level is not to exceed 7.6 m above top of pipe at low manhole. Low Pressure Air Test: The following formula is to be used to calculate the minimum required test time: $T = 1.02 DK/Q$ Where: T = shortest time, in seconds, for air pressure to drop from 24.13 KPa (3.5 psi) to 17.24 KPa (2.5 psi) K = 0.054 DL, but not less than 1.0 D = Pipe diameter, metres L = Length of pipe being tested, metres Q = 0.00046 m <sup>3</sup> /min/m <sup>2</sup> of internal surface (0.0015 ft <sup>3</sup> /min/ft <sup>2</sup> )

The total leakage from any test section shall not exceed 58Q m<sup>3</sup>/min (625Q ft<sup>3</sup>/min).

Concrete

Infiltration Test:

20.0 L/day/mm dia/km is allowable with average depth of groundwater a minimum of 0.6 m above crown of pipe. Where the average head of groundwater is 1.8 metres or more above the crown, the infiltration limit is increased by the ratio of the square root of the actual head to a base head of 1.8 metres.

Exfiltration Test:

20.0 L/day/mm dia/km is the combined allowable exfiltration from pipe and manholes when average head on the test section is 0.9 metres above crown of pipe or groundwater table, whichever is higher.

Exfiltration limit is increased by the ratio of the square root of the actual head to a base head of 0.9 metres when the average head on the test section is greater than 0.9 metres above crown of pipe or groundwater table, whichever is higher.

Low Pressure Air Test:

Same as for PVC pipe except  $Q = 0.00009 \text{ m}^3/\text{min}/\text{m}^2$  of internal surface ( $0.003 \text{ ft}^3/\text{min}/\text{ft}^2$ ).

### C3.7 Service Connections

- .1 The minimum size of a sanitary sewer service connection to a single family dwelling shall be 100 mm inside diameter. Each lot shall have its own separate sanitary service connection.
- .2 The minimum grade on the service line shall be 2.00%. The maximum length shall be limited to 15.0 m from the main to the property line.
- .3 Connection to a main sewer line shall be by means of a wye fitting. Saddles are allowed only for service connections to existing mains. T-fitting service connections for sanitary sewer will be allowed provided they discharge into the top half of the main.
- .4 Service pipe shall be PVC SDR 28 building service pipe conforming to CSA Specification B 182.1, latest revision thereof.
- .5 Minimum depth of cover shall be 2.60 m to the obvert at the property line.
- .6 Where sewer services are required to connect to mains in excess of 4.50 m deep, risers shall be installed
- .7 Sewer services shall be extended beyond the property line and terminate 3.0 m inside the lot. All services shall be properly capped.

- .8 All sewer services shall be installed using Class B bedding.
- .9 Red painted stakes of size 50 mm x 100 mm shall be extended from the end of the service connection to a minimum of 0.50 m above ground level.
- .10 Services shall be placed so that when facing the lot from the street the water service shall be on the right side of the sewer service.
- .11 Services shall be located such that they do not conflict with driveway locations.
- .12 Sanitary service inspection chambers (as manufactured by Le-Ron Plastics) shall be installed at the property line for each service. The inspection chamber shall be completed with riser pipe, locking 1C lid and metal bolt.

END OF SECTION C

D WATER DISTRIBUTION SYSTEM

D1 NETWORK ANALYSIS

- .1 The Developer shall perform an hydraulic network analysis for the proposed development unless the Town approves otherwise.
- .2 The criteria for network analysis shall be as follows:
  - .1 The maximum value of "C" in the Hazen-Williams formula shall be 120 regardless of pipe material for diameters less than 250 mm.
  - .2 The minimum diameter for distribution mains shall be 150 mm for residential development unless one or more hydrants are located on the line in which case the minimum diameter shall be 200 mm. For commercial/industrial development minimum water main size shall be 250 mm.
  - .3 Per capita design consumption:
    - .1 Average Day Demand 450 litres/day
    - .2 Maximum Day Demand 900 litres/day
    - .3 Peak Hour Demand 1350 litres/day
  - .4 Design population shall be the ultimate population for the area under construction.
  - .5 An analysis shall be made for peak hour demand and the mains shall be sized such that there shall be a minimum residual pressure of 280 KPa at ground level at any node in the network.
  - .6 A separate analysis shall also be made for maximum day demand plus a fire flow of 18,000 litres per minute at a node adjacent to a high value property, e.g. school or shopping centre. The minimum residual pressure at any node in the system shall be 140 KPa at ground level under this situation.
  - .7 Fire flow conditions within a residential area shall be analyzed using the criteria contained in the most recent edition of Fire Underwriters Survey. The Developer must take into consideration the architectural control features (i.e. house size and shake roofs) which may impact on the fire flow requirements.
  - .8 All calculations, schematic diagrams, computer printouts, etc., shall be submitted together with the design plans.
  - .9 New subdivisions shall be designed and constructed such that the water distribution and transmission systems through the area shall be looped.
  - .10 Distribution lines must all be looped except those serving single residence cul-de-sacs of less than 120 m.



## D2 MATERIALS

### D2.1 Water Mains

- .1 Minimum Size - 150 mm for Residential - 250 mm for Commercial
- .2 Pipe materials for use in the water main system shall conform to applicable CSA, AWWA and ASTM recommendations. Pressure ratings for the water main pipe shall be determined by the applications and conditions the pipe shall be subjected to.
- .3 Pipe material shall be polyvinyl chloride C-900 Class 150 DR-18.

### D2.2 Hydrants

- .1 Hydrants shall be of a style and make acceptable to the Town Engineer and shall:
  - .1 be compression type conforming to AWWA Specification C502, latest revision, for dry barrel fire hydrants,
  - .2 include two hose nozzles,
  - .3 include one pumper connection,
  - .4 have threads on hose and pumper connections which are the same as on existing hydrants in the Town,
  - .5 have hydrant body painted fire red in colour,
  - .6 hydrants shall be A.V.K. Model 2700, pumper gage 33B, nut style #6,
  - .7 hydrant buried components to be asphaltic coated or approved equal.

### D2.3 Valves

- .1 Gate Valves
  - .1 Valves shall be iron body gate valves with a non-rising spindle, which open by turning in a counter clockwise direction. All valves shall conform with AWWA Specification C509, latest revision, for operation and materials.
  - .2 Cast iron, asphalt or epoxy coated valve boxes of the Norwood Type "A" shall be required on all valves.
  - .3 Extension stem to be 25 mm square mild steel with 50 mm operating nut and flange suitable for 3.0 m bury,
  - .4 valves shall be resilient seated A.V.K. gate valves complete with stainless steel bolts and nuts and shall be asphaltic coated or approved equal.

## D2.4 Service Connections

- .1 Service pipe shall be of type K copper AWWA 800.
- .2 Residential services shall be 20 mm diameter unless the length of the service, measured from the main to the property line, is greater than 20.0 m in which case 25 mm diameter shall be used. Non-residential service connections shall be sized according to anticipated user requirements.
- .3 Corporation main stop shall be Cambridge Brass (EMCO) compression type conforming to ASTM C800, stainless steel service clamps with double stainless steel straps shall be used with all main stops for services larger than 25 mm.
- .4 Curb stop shall be copper to copper curb valve, Cambridge Brass (EMCO) ball valve with stop and drain.
- .5 Curb stop boxes shall be epoxy coated and the rod shall be stainless steel. Service boxes and rods shall be Norwood C100 for sizes up to 25 mm and Norwood C200 for sizes 32 mm to 50 mm.

## D3 INSTALLATION

### D3.1 Water Mains

- .1 Minimum depth of cover shall be 2.75 metres to the obvert below finished ground elevation.
- .2 Class "B" bedding shall be used for all water mains except where otherwise approved by the Town.

### D3.2 Compaction in Trench

- .1 In all new subdivisions it shall be the Developer's responsibility to ensure that utility trenches are adequately compacted. Within the road right-of-way 98% Standard Proctor Density shall be required; 95% Standard Proctor Density in all other areas. In existing subdivisions, the utility companies shall be responsible to ensure adequate compaction in utility trenches for any new installations or modification of existing lines.

### D3.3 Inspection and Testing

- .1 Prior to the initial acceptance of the project, all water mains shall be tested for leakage in accordance with AWWA C603, latest revision.

- .2 Prior to the initial acceptance of the projects, water mains are to be disinfected in accordance with AWWA C651 continuous feed method. Procedural method of disinfection includes, chlorine concentration calculations and contact times are to be submitted to the Town for acceptance. Upon completion of the disinfection one bacteria sample is to be submitted for each 90 linear metres of water main installed unless otherwise approved by the Town.
- .3 Prior to initial acceptance of the project bacteriological testing shall be carried out on all water mains.

#### D3.4 Hydrants

- .1 Maximum allowable spacing between fire hydrants shall be 150 m in single family residential areas and 90 m in multiple family residential, school or industrial/commercial areas.
- .2 Hydrants shall be set so that the bottom flange is approximately 50 mm above final ground elevation at the hydrant.
- .3 Hydrants must have breakaway flanges installed at the base of the body and must not extend below the ground grade line.
- .4 Installation shall be at the beginning of the curve of the curb return at the corners of intersections or at the extension of property lines.
- .5 In cul-de-sacs of 75 m in length or less, the hydrant shall be installed at or near the intersection of the intersecting street.

#### D3.5 Valves

- .1 Distribution main valves shall be located as follows:
  - .1 on the projection of property lines,
- .2 Distribution main valves shall be located such that in the event of a shutdown:
  - .1 no more than two hydrants are taken out of service,
  - .2 no more than four valves are required to affect a shutdown,
  - .3 maximum length of a dead end line is 120 m,
  - .4 no more than 25 single family units are involved in a shutdown, and
  - .5 commercial sites loop the main feeder with at least one valve on the loop.
- .3 Valves on hydrant leads are to be located in the boulevard area. All hydrants must be separated from the distribution system by a valve located 1.0 metres from the hydrant.

- .4 Valve boxes complete with operating extension stems and rock disk nut are required on all valves.
- .5 The top of the valve box is to be set 100 mm below final grade elevation on gravel areas and between 5 to 15 mm below finished grade on paved areas.
- .6 The rock disk nut shall not be more than 600 mm below finished grade.
- .7 Valves shall be of the same size as the main.
- .8 Sliding type cast iron valve casing shall be installed over each valve.
- .9 A water main in a cul-de-sac which exceeds 120 m in length must be looped to an adjacent water main through a Public Utility Lot. The PUL shall be a minimum of 4.0 metres wide with provision for a 1.0 m easement on each side of the PUL.

#### D3.6 Water Service Connections

- .1 Tapping for service connections shall be done with full operating pressure in the main unless otherwise approved by the Town.
- .2 Each service connection shall be tapped into the upper portion of the water main at least 45 degrees from the vertical and utilize a corporation stop.
- .3 Service pipe from the main to the curb cock shall be installed to provide a minimum depth of cover 2.6 m below finished road grade.
- .4 Curb cocks shall be located such that they do not conflict with driveway locations. Curb cocks are not to be placed in concrete driveways or sidewalks. Curb cocks shall be located 0.15 metres from the property line within the right-of-way.
- .5 Each residential dwelling unit must have a separate service.
- .6 Services shall be placed so that when facing the lot from the street, the water service shall be on the right side of the sewer service.
- .7 The symbol CC shall be stamped in the sidewalk opposite the location of the curb cock.
- .8 All proposed school sites shall be provided with a water service. The size, type and location will be determined by Town.
- .9 Water services shall be extended beyond the property line and terminate 3.0 m inside the lot. All water service ends shall be wrapped with an approved filter fabric.

END OF SECTION D

E STORM DRAINAGE SYSTEM

E1 MINOR SYSTEM

E1.1 Design Criteria

- .1 The Rational Method shall be used in the design of storm sewers as follows:

$$Q = CIA/360$$

Where: Q = the quantity of runoff in cubic meters per second.  
I = the intensity of rainfall in millimetres per hour.  
A = the contributing area in hectares.  
C = the runoff coefficient.

- .2 Rainfall data shall be taken from the nearest available intensity-duration-frequency curves.

- .3 The following runoff coefficients shall be used:

LAND USE

RUNOFF COEFFICIENT, C

Parks, reserves and school grounds	0.15
Single Family Residential	0.40
Multiple Family Residential	0.60
High Density Residential	0.70
Commercial	0.70
Industrial	0.70

- .4 Compatible computer modelling shall be required by the Town for areas greater than 65 hectares.
- .5 Maximum inlet time of 15 minutes shall be used. The use of longer inlet times requires the prior approval of the Town.
- .6 The storm sewer shall be designed to accommodate the 5 year return storm without sewer surcharging.
- .7 The minimum and maximum flow velocities in any sewer shall be 0.60 m/s and 3.0 m/s, respectively. Designs containing velocities in excess of 3.0 m/s shall require special provisions and the approval of the Town.
- .8 Pipe sizing shall be determined by utilizing Manning's Formula, using an "n" value of 0.013.

## E2 MATERIALS

### E2.1 Sewer Mains and Leads

- .1 Pipe for storm sewer mains shall be concrete pipe (sulphate resistant cement) conforming to ASTM C14 non reinforced concrete pipe; or ASTM C76 reinforced concrete pipe, latest revisions thereof.
- .2 PVC pipe, ASTM D3034, SDR35 will be allowed for mains and leads up to 375 mm diameter.
- .3 Ultra Rib P.V.C. pipe will be permitted.

### E2.2 Catch Basins

- .1 Catch basin frames and covers shall be required to provide sufficient inlet capacity. Standard models to be as follows:
  - .1 top inlet round top catch basins Norwood F-38 or Norwood F-39 for lanes and alleys,
  - .2 for curb and gutter Norwood F-51 without side inlet for all locations,
  - .3 other models shall require approval by the Town.

### E2.3 Manholes

- .1 Manhole sections shall be precast reinforced concrete sections conforming to ASTM C478, latest revision thereof.
- .2 Manhole frames and covers shall be Norwood NF 80 cast iron conforming to Class 20 ASTM A48, latest revision thereof.
- .3 Manhole steps shall be standard safety type, of hot dipped galvanized iron or aluminum.

## E3 INSTALLATION

### E3.1 Sewer Mains

- .1 The minimum size for storm sewer mains shall be 300 mm inside diameter
- .2 Minimum depth of cover shall be 1.2 metres to obvert.

### E3.2 Catch Basin Leads

- .1 The minimum size of catch basin leads shall be 250 mm inside diameter.
- .2 The maximum length of a catch basin lead shall be 30 meters. A catch basin manhole shall be required at the upper end if the lead exceeds 30 metres.
- .3 The minimum grade on a catch basin lead shall be 1.00%.

- .4 Minimum depth of cover shall be 1.2 metres to obvert.
- .5 All leads shall be connected to a main line manhole or a catch basin manhole.

### E3.3 Catch Basins

- .1 The maximum distance between catch basins shall be 150 m.
- .2 Spacing and capacity of catch basins shall be such that ponding shall not occur during a 1:5 year storm.
- .3 The minimum inside diameter for a catch basin barrel shall be 900 mm.
- .4 The minimum sump depth in a catch basin shall be 600 mm.

### E3.4 Manholes

- .1 The minimum size of storm manholes shall be 1200 mm, inside diameter.
- .2 Manhole bases shall be precast slabs, concrete poured bases, vaults or precast tees.
- .3 All precast manholes shall be perched when the main size is 600 mm to 1050 mm inside diameter unless otherwise approved by the Town.
- .4 Tee riser manholes shall be used when the mains are over 1050 mm inside diameter unless otherwise approved by the Town.

### E3.5 Compaction in Trench

- .1 Accepted bedding material shall be compacted to a minimum 98% Standard Proctor Density.
- .2 In all new subdivisions it shall be the Developer's responsibility to ensure that utility trenches are adequately compacted. Within the road carriage way 98% Standard Proctor Density shall be required; 95% Standard Proctor Density in all other areas. In existing subdivisions, the utility companies shall be responsible to ensure adequate compaction in utility trenches for any new installations or modification of existing lines.
- .3 Backfilling shall be carried out using selected material compacted in 150 mm layers.

### E3.6 Inspection and Testing

- .1 Refer to Section C3.5.

E4 MAJOR SYSTEM

E4.1 General

- .1 When the minor system capacity is exceeded the major system must provide a continuous route for runoff water to follow. Generally major system routing shall utilize roadways and open channels and be enhanced by compatible lot grading.
- .2 The major system shall accommodate a 1:100 year storm condition with maximum surcharging in the roadway gutter of 200 mm..
- .3 If downstream constraints require a gutter flow in excess of 200 mm, special modelling and design calculations shall be submitted to the Town for review. The Town shall determine the extent, if any, of a relaxation of the maximum 200 mm gutter flow standard on an individual basis.

END OF SECTION E



**F PARK DEVELOPMENT**

**F1.1 Definitions**

- .1 Park development means boulevards, buffer strips, cul-de-sacs, utility lots, park reserves, traffic islands and tot play areas.
- .2 Boulevards means that area between the property line and road curb.

**F1.2 Development**

- .1 The Developer shall submit to the Town detailed plans for park development which shall include:
  - .1 Existing and proposed elevations.
  - .2 Direction of drainage.
  - .3 Proposed size, location and type of trees and shrubs.
  - .4 Layout and design of play equipment
- .2 The Developer shall be responsible for landscaping and planting grass in all park development areas.
- .3 All park developments shall coincide with development of the subdivision and shall be completed within (12) twelve months of the commencement of development unless otherwise agreed at the time of the signing the development agreement.
- .4 Stockpiling of soil or construction materials on park development areas shall be prohibited unless special written dispensation has been granted by the Town.
- .5 Park development shall be seeded at a rate of one kilogram per 50 square metres with Canada Number One seed mixed to the following proportion by weight:
  - .1 70 % Creeping Red Fescue and 30 % Kentucky Blue Grass or other approved mixture.
- .6 Soil preparation, fertilizer and other treatment shall be in accordance with Alberta Agriculturist Recommendations for Valleyview Area.
- .7 One sewer service and one water service complete with surface connection shall be installed at an approved location to each designated public use or playground park area.
- .8 One water service complete with surface connection shall be installed at an approved location to each ornamental park.

- .9 Park development may be planted with trees (evergreen) at a maximum spacing of 9.0 metres, if requested by the Town in writing at the time of the signing the development agreement.
- .10 The developer shall be responsible for the maintenance of all buffers, cul-de-sacs, utility lots, boulevards, and park reserves until a good growth of grass has been established or for a period of one year, which ever is longer.

END OF SECTION F

**G GAS, POWER AND TELEPHONE SERVICES**

**G1.1 Gas, Power and Telephone**

- .1 The gas, power and telephone services to be installed shall be arranged between the developer and the respective utility companies and shall be installed underground. Any cost for these services by the respective utility companies shall be paid by the Developer.
- .2 Each utility company shall submit plans of the proposed works to the Town for approval prior to construction. All gas, power and telephone utilities shall conform to the same standards for trench compaction and clean up as sewer and water utilities.

**G1.2 Street Lighting**

- .1 Street lighting shall be arranged by the developer to a standard of lighting comparable to existing standards within the Town and specifications currently used by Alberta Power Ltd. within the Town.
- .2 Street light cables shall be installed underground and an acceptable type of steel post with fixture shall be used. Steel posts shall be low maintenance brown in colour.
- .3 The Town will pay rental charges to the utility company for the operation of street lights after the development construction has been acceptance by the Town.
- .4 The Town shall approve the street lighting layout prior to installation.

END OF SECTION G

APPENDIX I  
PLAN STANDARDS

## APPENDIX 1

### PLAN STANDARDS

#### 1 DESIGN DRAWINGS

All detailed engineering plans submitted for review and approval to the Town must comply with the following specifications:

##### 1.1 Drawing Techniques

- .1 Points of drawing technique that are significant to the preparation of drawings are as follows:
  - .1 Clarity and legibility will be the governing criteria when preparing drawings.
  - .2 Care should be taken in ensuring balanced distribution of detail throughout the drawing.
  - .3 Letters and figures will be clearly legible, 2 mm size or larger (Leroy or equivalent), well spaced, properly formed and proportioned.
  - .4 Lines will be uniform in weight and density.

##### 1.2 Scales

- .1 Plans will be drawn to the following scales:
  - .1 Overall Plans, 1:1000
  - .2 Plan/Profile, Horizontal 1:500, Vertical 1:50
  - .3 Cross Sections and Details As Required

##### 1.3 Geodetic Datum

- .1 Elevations will be relative to Geodetic datum. Reference bench marks and elevations will be identified on the Index Plan.
- .2 A north arrow will be shown on each drawing. In general, north arrows should be directed towards the top of the plan.

##### 1.4 Plan Size

- .1 The standard A-1 drawing size (594 mm by 841 mm) will be used.

## 2 PLAN AND PROFILE DRAWINGS

### 2.1 General

- .1 Plans are to be drawn to a scale of 1:500 horizontal and 1:50 vertical.
- .2 Existing and proposed features are to be clearly delineated.
- .3 All drawings must clearly show the following in the title block:
  - .1 developer's/owner's name,
  - .2 consultant's name,
  - .3 subdivision name including staging and/or phasing,
  - .4 drawing name,
  - .5 drawing number and job number, if applicable,
  - .6 revision number,
  - .7 horizontal and vertical scales,
  - .8 space for the signature of the designer, draftsman, checker and approving principal,
  - .9 space for the number, date, description, designer and approving principal of all revisions,
  - .10 space for issue dates including preliminary, approval, tender, construction, as built, and in addition the date and initials of person approving each issue must be shown,
  - .11 space for professional stamps and permits.

### 2.2 Road and Right-of-Way Information

- .1 The following information is to be shown on the plan portion of the drawing:
  - .1 legal subdivision information including lot and block numbers,
  - .2 alignment of proposed street easement or right-of-way; name or temporary designation of the above,
  - .3 alignment of immediately adjacent existing and proposed streets, walks, lanes, ditches, interim or temporary connections, utility rights-of-way, easements and reserves. Identification of the above is to be by name (i.e. streets) or ownership (i.e. easement, rights-of-way),
  - .4 existing and proposed surface features such as roads, curb and gutter, sidewalk, walkway connections, wheelchair ramps, bus stop pads and boulevard areas,
  - .5 dimensions, relative to property lines, of roads and right-of-way widths, sidewalk and curb and gutter locations, and boulevard locations,
  - .6 horizontal curve data including chainages of the BC and EC, delta angle, radius, chord length and arc length for centre line of each roadway. All curb returns must show the radius. Note, alternatively this information can be shown in a table format.

- .7 elevations along curb and gutter of all changes in vertical alignment,
  - .8 elevations of the BC and EC of all curb returns, including the grades and distances around the curve, and
  - .9 location of all existing survey monuments, if applicable.
- .2 The following information is to be shown on the profile portion of the drawing:
- .1 existing ground profile along the centre line of the proposed roadway, lane or utility as required,
  - .2 proposed top of curb elevations including proposed grade to two (2) decimal places,
  - .3 vertical curve information including chainage and elevations of BVC, PVI and EVC; external value, e; length of curve; elevation and chainage of low point of sag curves and high point of crest curves, k values,
  - .4 lip of curb and lane grade, if applicable, at all intersecting proposed and existing roads, and
  - .5 chainage of all BC and EC curb returns.

### 2.3 Sanitary and Storm Sewer Information

- .1 The following information is to be shown on the plan portion of the drawing:
- .1 alignment of mains including distance from property lines,
  - .2 diameter of mains,
  - .3 all appurtenances such as manholes, catch basin frame and cover type, plugs, cleanouts, inlet and outlet structures,
  - .4 leads between catch basins and manholes,
  - .5 elevations of catch basins at gutter,
  - .6 direction of flow,
  - .7 service lateral location, and
  - .8 radius of curved sewers.
- .2 The following information is to be shown on the profile portion of the drawing:
- .1 vertical alignment of proposed mains along the profile,
  - .2 elevation and diameter of existing and proposed mains and other utilities crossing or intersecting the profile and which will impact on the construction. Where possible these should be verified in the field.
  - .3 diameter, length and percent grades of sewer mains between manholes,
  - .4 inverts of all pipes connecting to a manhole,
  - .5 size, type and class of pipe,
  - .6 class of bedding,
  - .7 proposed rim elevations for all manholes,

- .8 capacity of sewer between manholes along with calculated flow and velocity in the particular section. Note, this may be provided in a table format on a separate sheet,
- .10 any special construction areas such as shored construction or limited space areas, and
- .11 chainage of BC and EC of curved sewers.
- .12 special appurtenances such as drop structures and safety platforms.
- .13 Radius and length of curve for curved sewers.

#### 2.4 Water Distribution Information

- .1 The following information is to be shown on the plan portion of the drawing:
  - .1 alignment of mains including distance from property lines,
  - .2 diameter of mains,
  - .3 all appurtenances such as hydrants, tees, bends, crosses, valves, blowoffs and plugs,
  - .4 service lateral location, and
  - .5 angled or cased sections.
- .2 The following information is to be shown on the profile portion of the drawing:
  - .1 vertical alignment of proposed mains along the profile,
  - .2 elevation and diameter of existing and proposed mains and other utilities crossing or intersecting the profile and which will impact on the construction. Where possible these should be verified in the field.
  - .3 top of pipe elevations at all tees, bends, crosses, plugs and grade changes,
  - .4 size, type and class of pipe,
  - .5 class of bedding,
  - .6 extent of work required to connect to existing mains

#### 2.5 Standard Detail Drawings

- .1 Standard detail drawings must be included as part of the set of engineering drawings for each project.
- .2 Standard size A-1 sheets will be used.
- .3 The scale of individual details will be commensurate with the amount of information to be shown along with clarity and legibility.



### 3 AS-BUILT DRAWINGS

#### 3.1 General

- .1 Clear full size prints of the as-built construction drawings and computer disks capable of being used with AutoCAD containing identical information must be submitted to the Town within one month of issuance of the Construction Completion Certificate. The information shall be submitted in 3 ring binders (two sets) complete with the location, year of construction, developer and contractor clearly identified on the spine and cover of the binder.
- .2 As-built drawings will provide all the information outlined in Section 2.
- .3 On as-built drawings submitted to the Town, the following information will be included on each drawing:
  - .1 date of construction completion,
  - .2 date on which as-built details were added, and
  - .3 signature and stamp of professional engineer approving as-built drawings,
  - .4 all makes, size and model of material used.

#### 3.2 Water and Sanitary Service Connection Information

- .1 A table on each plan/profile drawing shall be prepared giving the following information with respect to service connections.
  - .1 lot number,
  - .2 distance of service saddle or wye from downstream manhole, and
  - .3 invert elevation of sanitary service and top of pipe of water service at property line.
- .2 The service connection provided to each lot shall be shown on the plan and the location referenced to the property lot corner.
- .3 Riser connections will be shown on the profile portion of the plan/profile drawing.

#### 3.3 Standard Details

- .1 Standard detail drawings will be revised to reflect as built information.

END OF APPENDIX 1

**APPENDIX II  
SAFETY PROGRAM GUIDELINES**

**ACKNOWLEDGMENT OF SAFETY PROGRAM GUIDELINES  
FOR  
THE TOWN OF VALLEYVIEW**

I \_\_\_\_\_  
Name of Contractor, Consultant, Representative, Developer

of \_\_\_\_\_  
Company Name

\_\_\_\_\_  
Address

\_\_\_\_\_  
Project Description

We acknowledge receipt of the guidelines for the Town of Valleyview. I understand it is my responsibility on behalf of the contractor to ensure that these guidelines as well as appropriate federal and provincial regulations or municipal bylaws, are enforced during work at the above work place, it is understood that the regulations shall be exceeded when special hazards warrant this.

It is fully understood that the contractor is responsible for and will administer their own safety program, and all incident reports, safety inspection, and accident reports, will be made available to representatives of the Town of Valleyview as named below.

\_\_\_\_\_  
Town of Valleyview

Signed this \_\_\_\_\_ day of \_\_\_\_\_, 19 \_\_\_\_.

\_\_\_\_\_  
Signature

\_\_\_\_\_  
Witness

## Safety Program Guidelines for Contractors

### *Introduction*

The Town of Valleyview is committed to ensuring employee safety is an integral component of all construction activities. To meet our loss prevention objectives, a proper contractor safety program that complements the Town's program is essential.

These guidelines are to assist contractors in establishing and maintaining an acceptable safety program. The guideline is to serve as an example of minimum requirements for a contractor's safety program.

Contractors shall not assume these guidelines address every circumstance or that they will not warrant additional precautions. The Town expects contractors to adhere to their responsibilities as employers and to exercise sound judgement in the daily administration of safety procedures.

Contractors are responsible for and shall monitor the safety performance of their agents, employees and any subcontractor's employees. Nothing in this guideline relieves contractors of their legislated and moral responsibility and liability for work site safety.

### *Legislation*

The contractors shall comply with Federal, Provincial and local statutes; in particular, the Occupational Health and Safety Act and Regulations. Sufficient copies of the Occupational Health and Safety Act and Regulations shall be available at the work site.

### *Workers' Compensation and Insurance Coverage*

Where the Workers' Compensation Act applies, contractors are expected to maintain a current up-to-date account covering all workers involved in the project. Proof of account status may be required prior to commencement of the project. Appropriate insurance coverage for public liability and property damage is also required.

### *Commitment to Safety*

While engaged in work for the Town or while on Town directed or funded projects, the contractor shall actively promote safe working practices and shall analyze employee activities to identify risk and ensure appropriate precautions are in place to minimize the likelihood of an accident occurring.

Management shall develop and, if practical, post or distribute safety policies and procedures appropriate to the project activities.

*Safe Performance  
of Staff*

*Competent Workers*

*Enforcement*

*Inspections*

- In keeping with the Occupational Health and Safety Regulations, the contractor shall ensure that only competent workers or workers under the direct supervision of competent workers shall be permitted to carry out any work in the Town.
- A contractor is responsible for implementing an effective system of safety orientation and education for their staff.
- A contractor is responsible for ensuring that workers are familiar with and have access to copies of the applicable Occupational Health and Safety Regulations and of this document.
- Each contractor is responsible for conducting pre-commencement and ongoing qualification verification to ensure that workers have the necessary skill, knowledge, experience and where required, certification to perform the job safely and in accordance with any applicable legislation. This verification will be necessary for jobs employing:
  - drivers;
  - crane and hoise operators;
  - equipment operators;
  - first aiders or other emergency response staff;
  - shippers and transporters of dangerous goods; and
  - persons handling radioactive or explosive materials.
- Contractor supervision is responsible for ongoing assessment of employee competence and attitude and for enforcement of safety operating procedures.
- Contractor employees or supervisors who demonstrate a poor attitude toward safe work and safety procedures are not acceptable for work on Town projects.
- Contractor supervisors unwilling or unable to demonstrate good safety practices are not acceptable for work on Town projects.
- Contractors shall use a regular system of safety inspections to detect and correct hazardous conditions, safety violations and unsafe work practices.
- The Town will periodically participate in and provide support to contractors in their inspection programs.
- Copies of regular inspection reports shall be maintained and made available to the Town upon request.

### *Safety Representatives*

- In addition to regularly scheduled inspections, supervisors/foreman shall conduct continuous work site surveillance taking immediate action to rectify any observed unsafe conditions or actions.
- Contractors with 100 or more employees working on a project for the Town must employ a full-time safety representative.
- Contractors with 25 - 99 employees on site must designate one employee as a part-time site safety representative.
- Designated site safety representatives of a contractor on a Town project site shall meet at least once a month to discuss safety problems, inspections and exchange information.
- Minutes of the Safety Representatives meeting shall be kept and a copy shall be promptly forwarded to the Town, Occupational Health and Safety and to the nearest Alberta Labour office, as well as being posted at the work site.
- Where the project utilizes security and/or emergency medical services, both groups shall be represented at the Safety Representatives meeting.

### *Pre-Job Orientation*

Prior to commencement of the project or entry of the contractor's staff and equipment onto the project site, a pre-job orientation meeting shall be held between the contractor, developer and the Town for the project. The nature of hazards and any specific safety precautions required will be discussed. Where practical, representatives of all major subcontractors to be utilized by the contractor should be present at the meeting.

### *Accident Reporting/ Investigation*

- Contractors shall have an effective accident reporting and investigation system established and shall ensure that all staff are advised of the importance of prompt reporting and investigation of accidents.
- Accidents causing injury or having the potential for serious injury shall be reported by the contractor to the appropriate authorities in accordance with applicable Acts and Regulations.
- The Town shall be advised, by the fastest means available, of any serious injuries, accidents or situations having the potential to cause serious injury (as defined in the Occupational Health and Safety Regulations), and dangerous occurrences (as defined in the Transportation of Dangerous Goods Regulations) or reportable incidents under the requirements of the Energy Control Board.

*Emergency Services*

*Personal Behavior*

*Monthly Safety Summary*

- Contractors shall provide copies of accident reports to the Town upon request. Reportable accidents include:
  - personal injury (medical aid or disabling);
  - vehicle accidents;
  - spills or accidental release of products that may be potentially harmful to people or the environment;
  - fires or explosions; and
  - near misses having the potential to cause injury.
- Contractors shall conduct a pre-commencement evaluation of the project and ensure that suitable emergency response plans, equipment and training staff are available to handle emergencies that may arise. Copies of emergency response/ evacuation plans shall be made available to the Town upon request.
- Contractors shall maintain sufficient numbers of trained first aiders, first aid attendants, first aid supplies and emergency conveyances as required by the Occupational Health and Safety Act and Regulations.
- Contractors are responsible for pre-job contact with the local ambulance service to verify accessibility to the project. Where ambulance service is not available to the site, the contractor is responsible for providing suitable emergency conveyance as specified in the Occupational Health and Safety Act and Regulations.
- Contractors are responsible for ensuring that no employee or employees of any agents or subconsultants are allowed to enter the project site while under the influence of drugs or alcohol.
- Contractors are responsible for ensuring that the conveyance or use of firearms on site is prohibited unless prior written authorization has been granted by the Town.

Contractors shall provide the Town with a monthly summary of safety activities and incidents occurring on site.

The summary should include among other things:

- dates of safety meetings or talks;
- record of safety inspections conducted;
- summary of accidents and reportable incidents;
- any accident statistics (frequency, severity) compiled for the staff on this project;
- safety promotions or awards made; and
- summary of orders received pursuant to the Occupational Health and Safety Act.

***Equipment Standards***

Contractors are responsible for ensuring:

- equipment that they have fabricated or modified has been designed in accordance with good engineering principles and that a stamped and signed copy of the engineer's certification is available to the Town upon request;
- all equipment is in safe mechanical condition;
- no tools or equipment are modified in any manner that will reduce the original factors of safety or capacity;
- a regular inspection program is in place that will remove or "tag out" any defective tools and equipment immediately;
- no original guards are removed from equipment or tools;
- an effective maintenance program is in place that will maintain equipment in accordance with the manufacturer's recommendations.

***Staff Meeting***

A contractor shall conduct safety meetings with staff or through an established joint work site safety committee at least once a month while involved on the project.

Minutes, complete with attendance records, are to be kept for safety or joint work site safety committee meetings and are to be made available to the Town upon request.

Regular five-minute "tailgate" safety meetings are to be held by the contractor's foreman with all crews.

Contractor's safety representatives are expected to participate in regular meetings with the Town and with safety representatives from other contractors on site.



**APPENDIX III  
STANDARD DRAWING DETAILS**

# TOWN OF VALLEYVIEW

## STANDARD DRAWING DETAILS

### INDEX

FIGURE 1	THRUST BLOCK DETAILS
FIGURE 2	STANDARD FRAME AND COVERS FOR CB AND CBMH
FIGURE 3	TRENCH & CLASS 'B' BEDDING DETAIL
FIGURE 4	F-51 CATCHBASIN INSTALLATION DETAIL FOR CURBS
FIGURE 5	VALVE BOX DETAIL
FIGURE 6	STANDARD CATCH BASIN WITH SUMP
FIGURE 7	MANHOLE DETAIL
FIGURE 8	DROP MANHOLE DETAIL
FIGURE 9	CATCH BASIN MANHOLE
FIGURE 10	SANITARY SEWER SERVICE CONNECTION RISER
FIGURE 11	ROLLED CURB & GUTTER AND CROSSING DETAILS COMMERCIAL, LANE AND PRIVATE
FIGURE 12	150mm BARRIER CURB & GUTTER AND CROSSING DETAILS - COMMERCIAL, LANE AND PRIVATE
FIGURE 13	ROLLED MONOLITHIC CURB, GUTTER & SIDEWALK
FIGURE 14	150mm BARRIER MONOLITHIC CURB, GUTTER & SIDEWALK
FIGURE 15	ROLLED MONOLITHIC CROSSING DETAILS COMMERCIAL, LANE AND PRIVATE
FIGURE 16	150mm BARRIER MONOLITHIC CROSSING DETAILS COMMERCIAL, LANE & PRIVATE CROSSINGS
FIGURE 17	WHEEL CHAIR/BIKE RAMP DETAILS
FIGURE 18	SEPARATE SIDEWALK DETAILS
FIGURE 19	9.0m URBAN RESIDENTIAL STREET SECTION WITH MONO SIDEWALK
FIGURE 20	11.5m URBAN MINOR COLLECTOR STREET SECTION WITH MONO SIDEWALK
FIGURE 21	14.0m URBAN MAJOR COLLECTOR STREET SECTION WITH SEPERATE SIDEWALK
FIGURE 22	4.0m PAVED RESIDENTIAL LANE
FIGURE 23	TYPICAL FRONT LOT DRAINAGE TYPE A
FIGURE 24	TYPICAL SPLIT LOT DRAINAGE TYPE B
FIGURE 25	TYPICAL REAR LOT DRAINAGE TYPE C
FIGURE 26	OFF-LINE HYDRANT DETAIL
FIGURE 27	SINGLE SERVICE LAYOUT (NEW INSTALLATION)

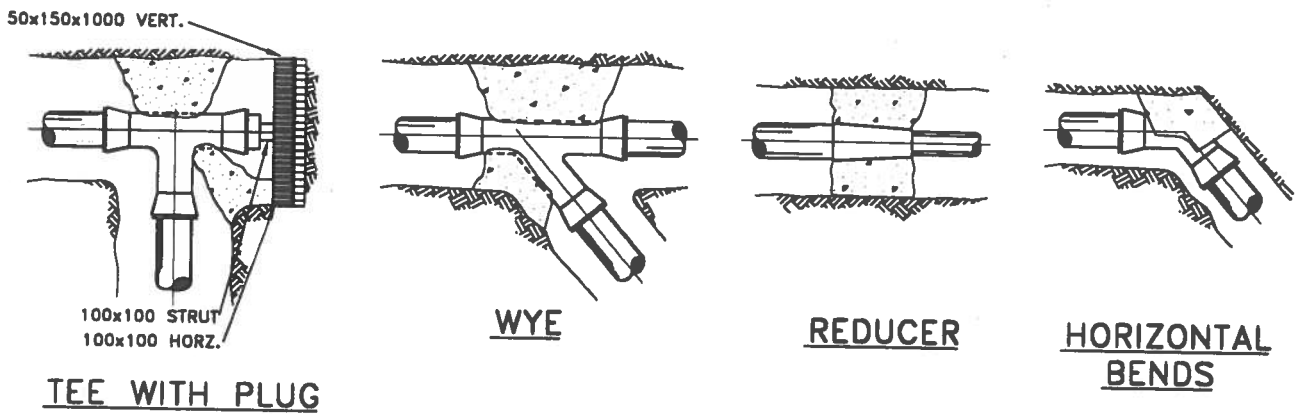
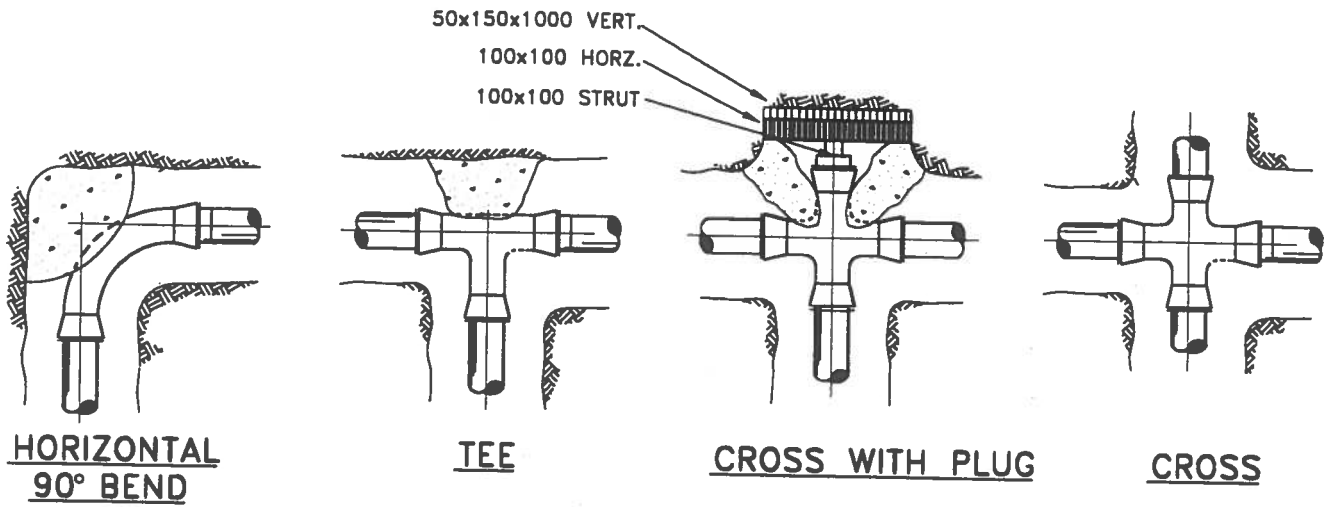

NOTE: THE REQUIRED BEARING AREA SHALL BE DETERMINED BY THE CONTRACTOR TO SUIT THE SOIL CONDITIONS.

NOTE:

1. ALL DIMENSIONS ARE GIVEN IN MILLIMETRES
2. ALL WOOD PRODUCTS TO BE TREATED
3. ALL FITTINGS TO BE WRAPPED IN POLY PRIOR TO POURING CONCRETE
4. ALL CONCRETE TO BE MIN. 25MPa @ 28 DAYS.

DATE: MARCH 1998

TOWN OF VALLEYVIEW

TITLE:

THRUST BLOCK DETAILS

ACAD - CIVIL DRAFTING STANDARD DETAILS

FIGURE:

1

TYPE NF-80 FLOATING MANHOLE FRAME AND COVER

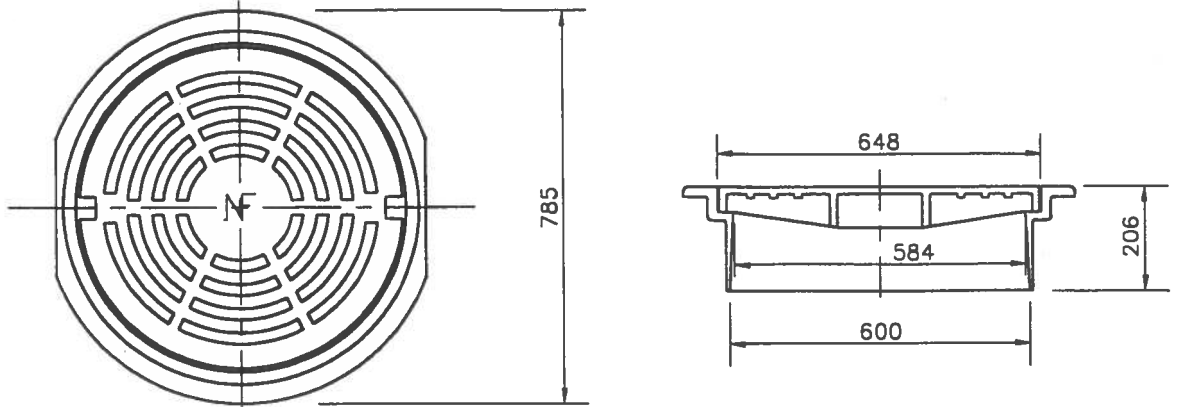

TYPE F-38 LANE PAVING CATCHBASIN MANHOLE FRAME AND COVER

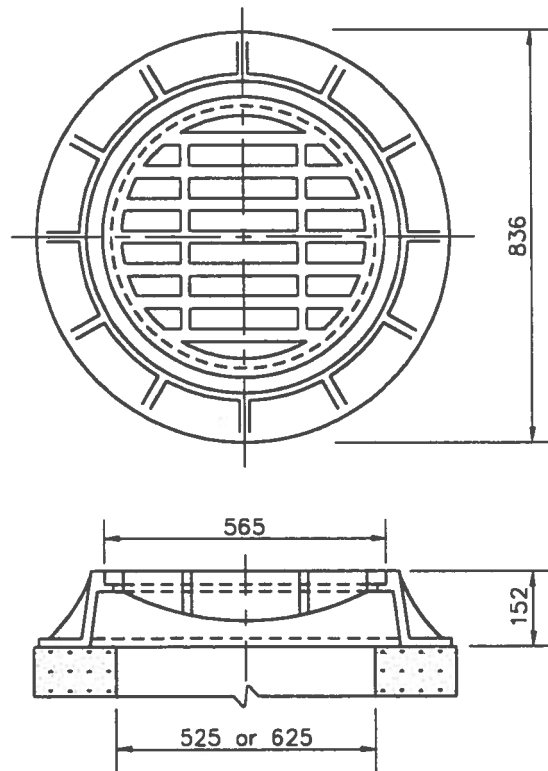

NOTES:

1. ALL DIMENSIONS IN MILLIMETRES UNLESS NOTED OTHERWISE

DATE: MARCH 1998	TITLE: <b>STANDARD FRAMES AND COVERS FOR CB AND MH</b>	ACAD - CIVIL DRAFTIN STANDARD DETAILS
TOWN OF VALLEYVIEW		DETAIL No.  2

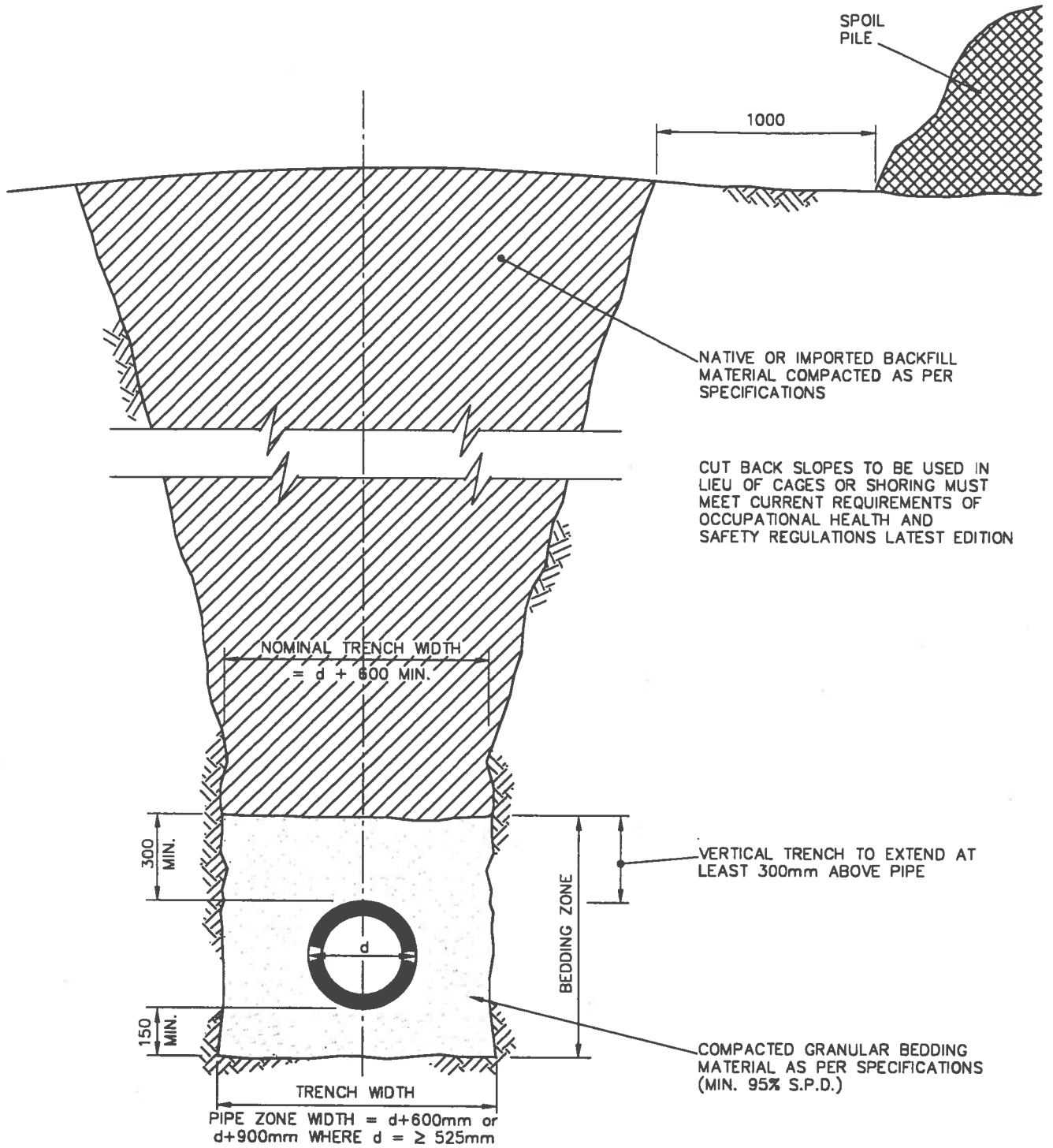

- NOTES: 1. ALL DIMENSIONS ARE IN MILLIMETRES UNLESS SHOWN OTHERWISE.  
 2.  $d$  = PIPE OUTSIDE DIAMETER

DATE: MARCH 1998

TOWN OF VALLEYVIEW

TITLE:

TRENCH & CLASS 'B' BEDDING DETAIL

ACAD - CIVIL DRAFTING STANDARD DETAILS

FIGURE:

3

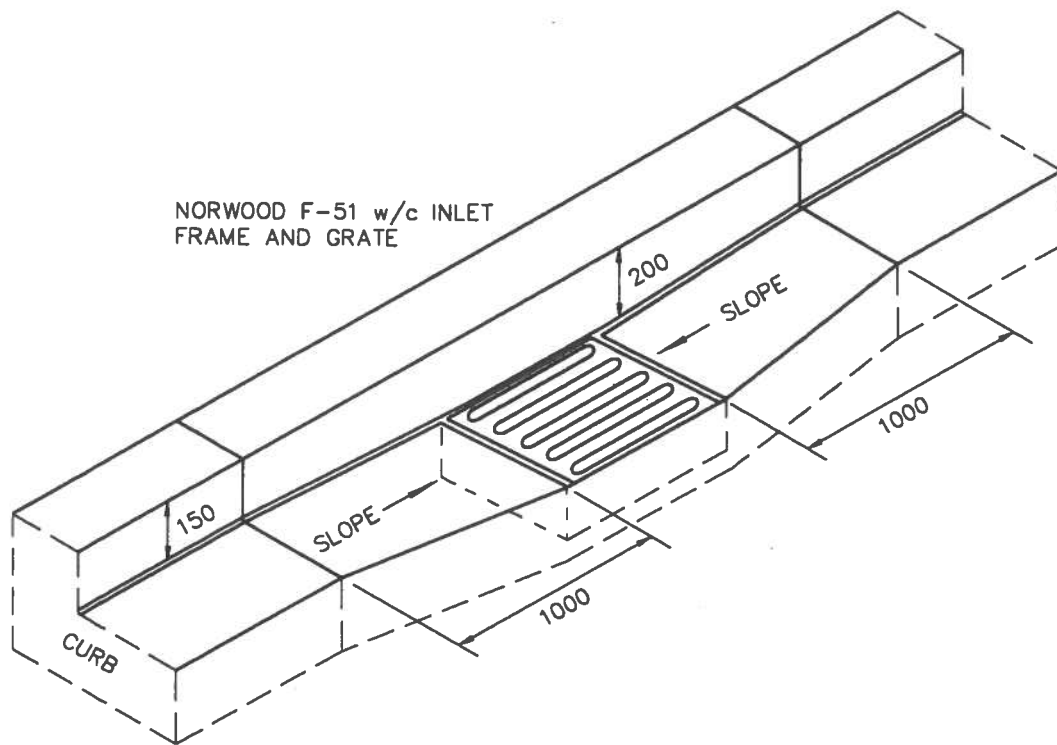

DATE:  
MARCH 1998

TOWN  
OF  
VALLEYVIEW

TITLE:  
**F-51 CATCHBASIN  
INSTALLATION DETAIL  
FOR CURBS**

ACAD - CIVIL DRAFTING  
STANDARD DETAILS

DETAIL No.

4

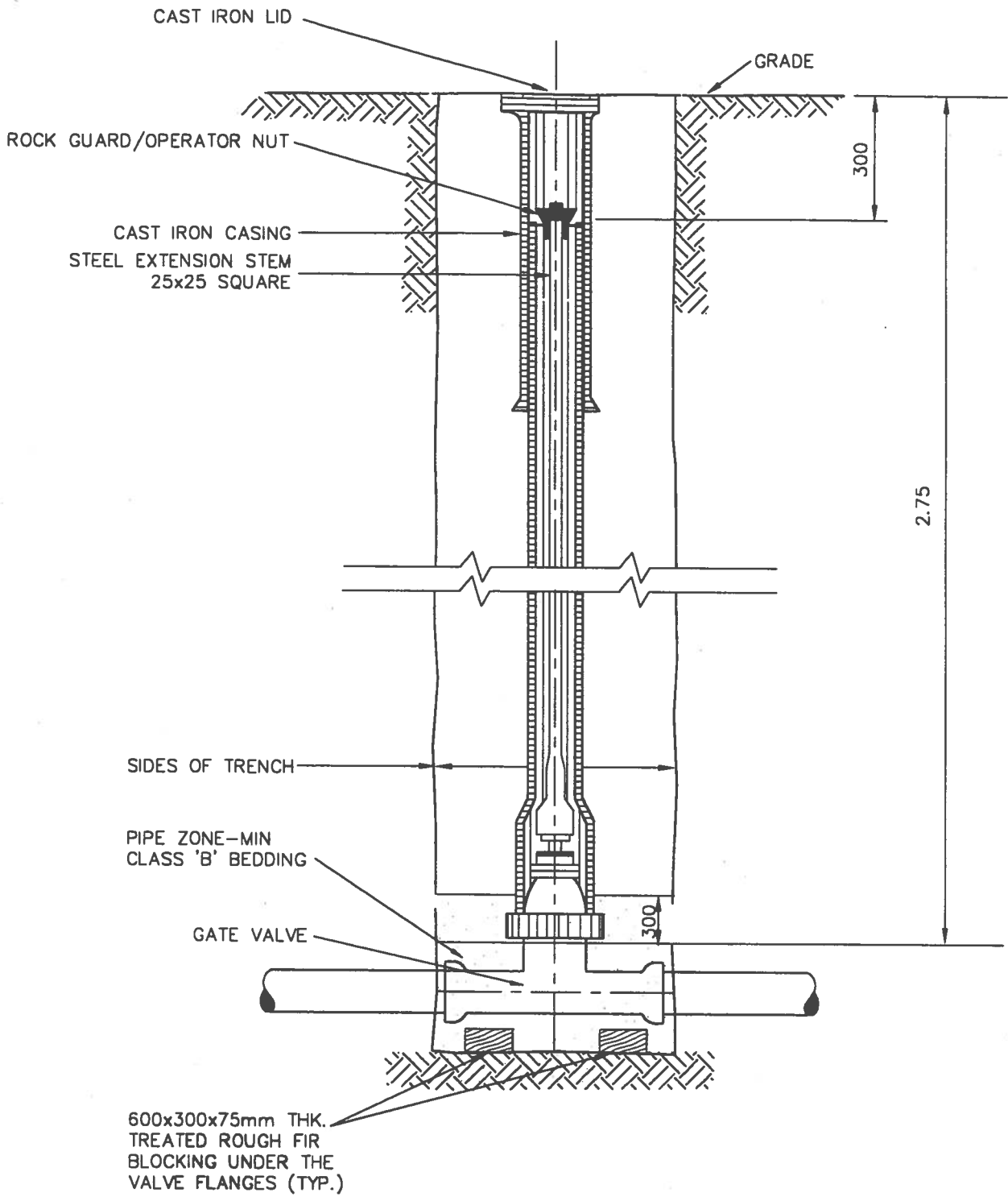

DATE: MARCH 1998	TITLE:	ACAD - CIVIL DRAFTING STANDARD DETAILS
TOWN OF VALLEYVIEW	VALVE BOX DETAIL	FIGURE:
		5

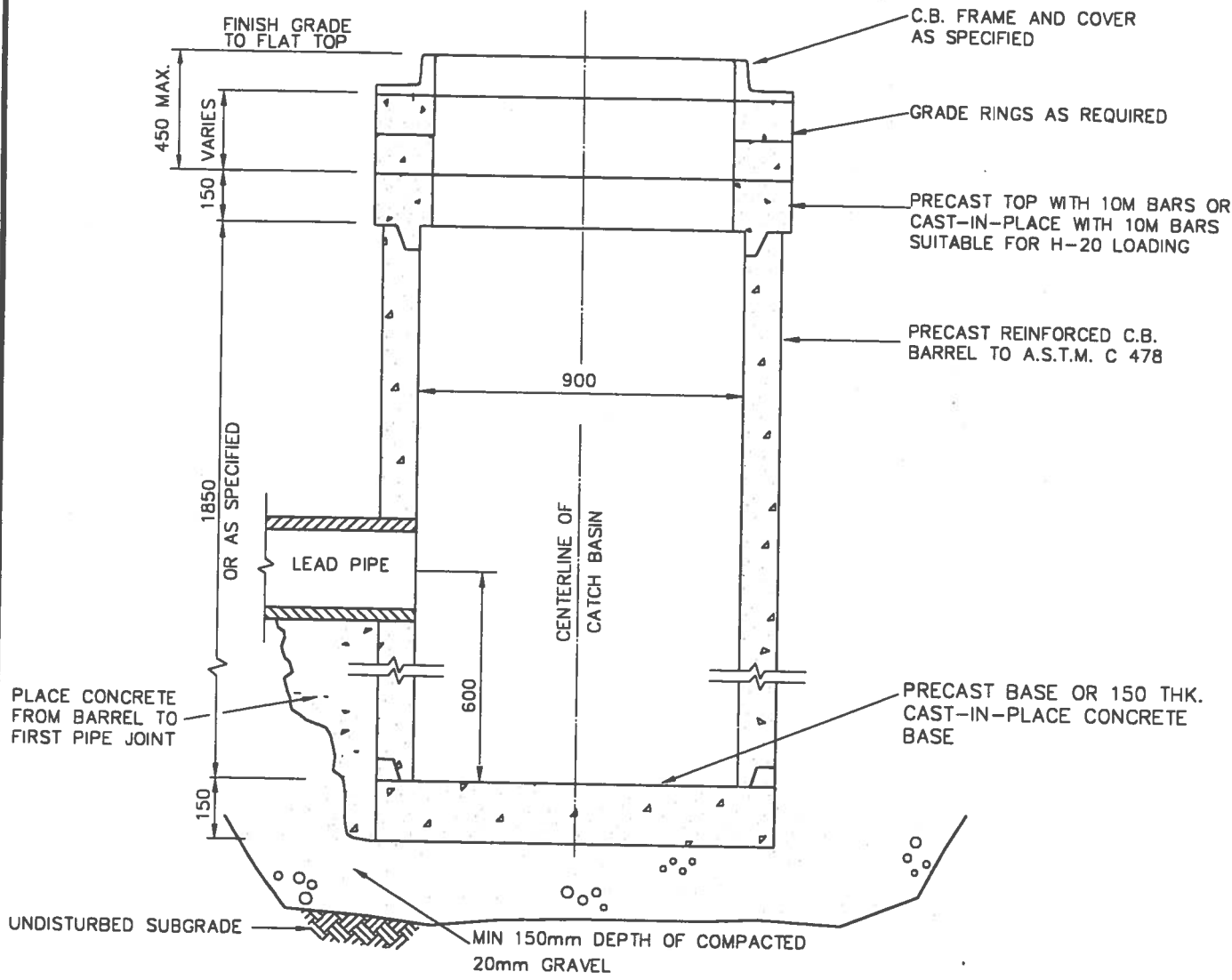

**NOTES:**

1. ALL CAST-IN-PLACE CONCRETE 25 MPa - 28 DAY STRENGTH  
ALL JOINTS TO BE MORTARED INSIDE & OUT
2. ALL DIMENSIONS ARE GIVEN IN MILLIMETRES

DATE: MARCH 1998	TITLE: <b>STANDARD CATCH BASIN WITH SUMP</b>	ACAD - CIVIL DRAFTING STANDARD DETAILS
TOWN OF VALLEYVIEW		FIGURE:  6



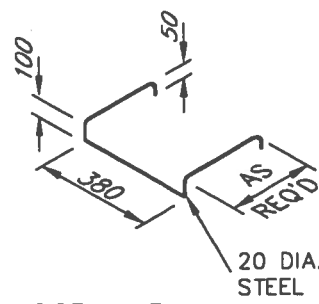
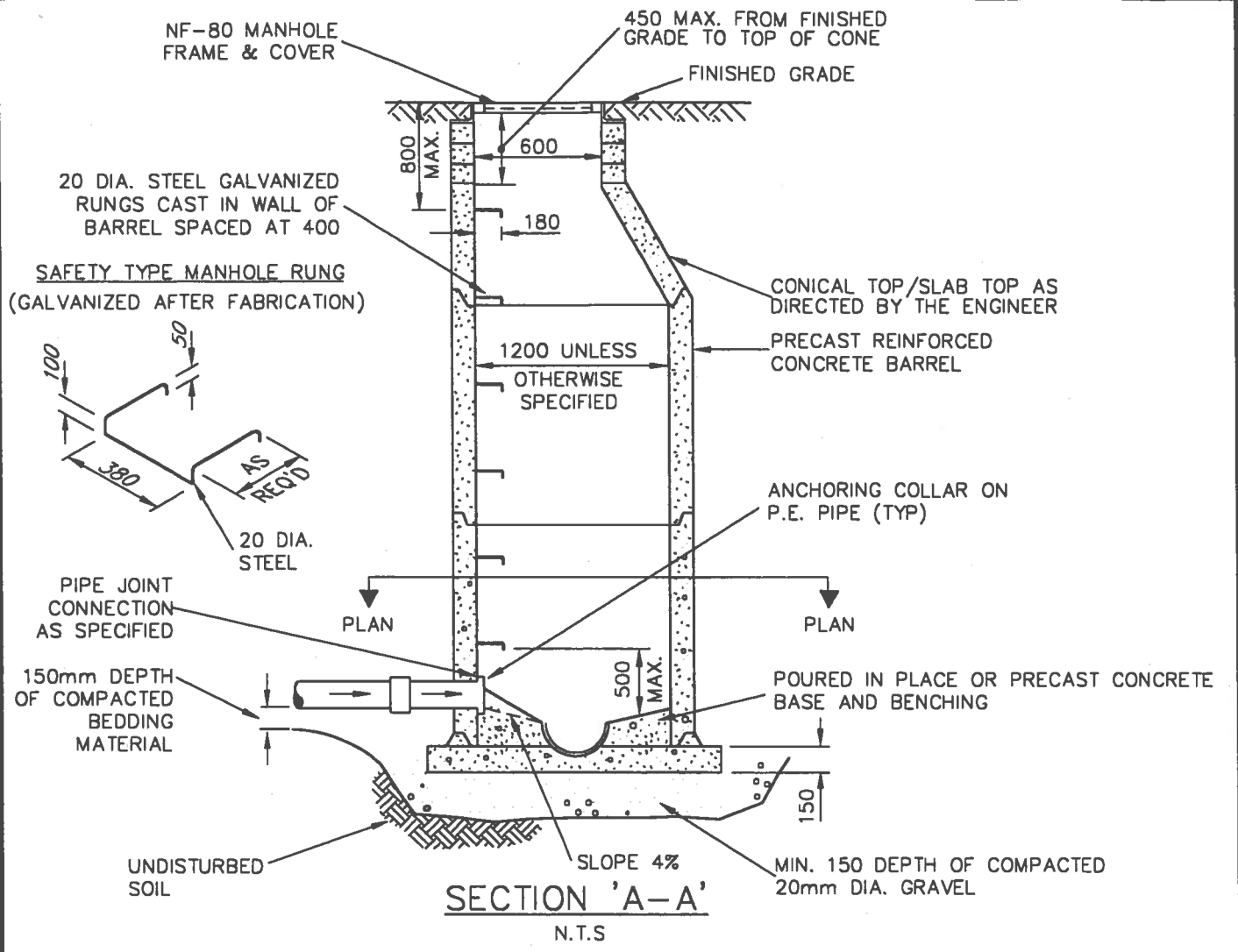

UNDISTURBED SOIL

**SECTION 'A-A'**  
N.T.S.

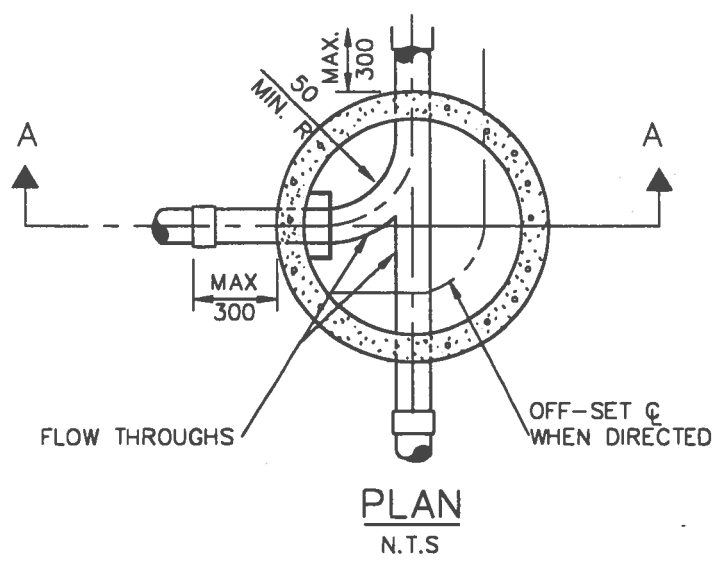

**NOTES:**

1. ALL PRECAST MANHOLES MUST CONFORM TO A.S.T.M. SPECIFICATIONS C478
2. POURED IN PLACE CONCRETE SHALL HAVE 28 DAYS COMPRESSIVE STRENGTH 20 MPa.
3. ALL JOINTS MORTARED INSIDE & OUT
4. FORM FLOW THROUGH IN PARTIALLY SET CONCRETE AND TROWEL SMOOTH
5. ALL DIMENSIONS GIVEN IN MILLIMETRES.
6. MAX. DIST FROM RIM TO TOP RUNG IS 800mm.
7. BACKFILL MH. WITH SELECT NATIVE MATERIAL.

DATE: MARCH 1998	TITLE: <b>MANHOLE DETAIL</b>	ACAD - CIVIL DRAFTING STANDARD DETAILS
TOWN OF VALLEYVIEW		FIGURE: 7

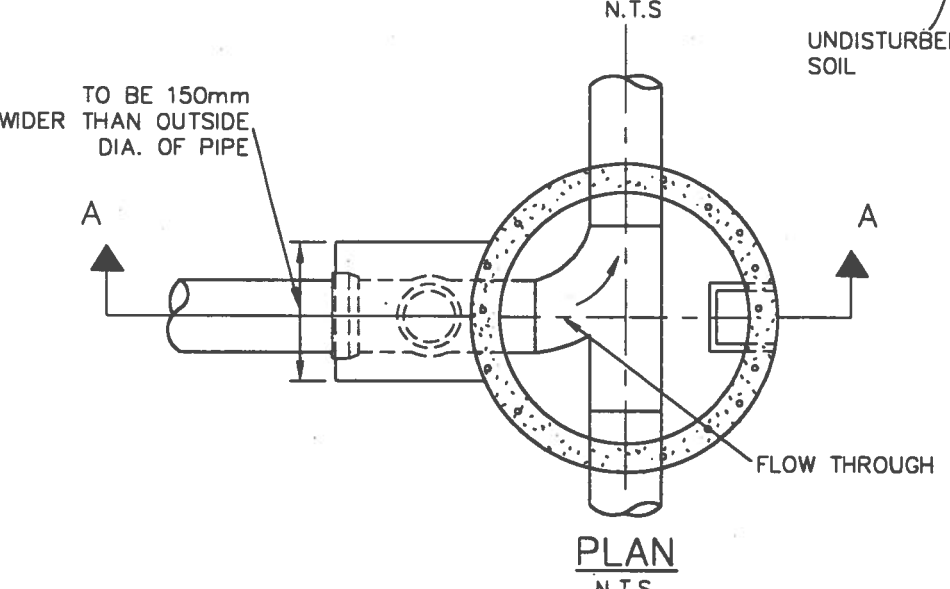
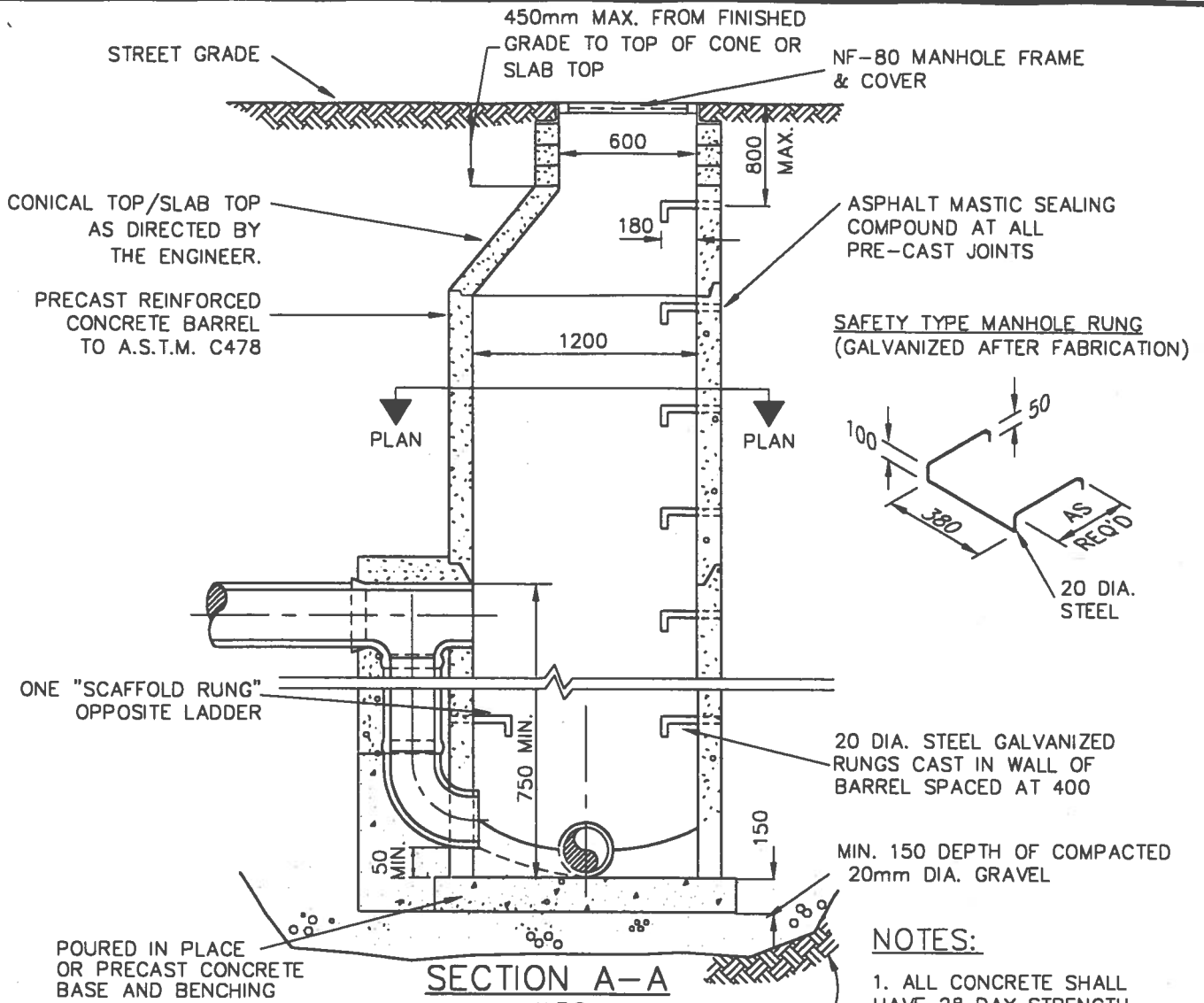

- NOTES:**
1. ALL CONCRETE SHALL HAVE 28 DAY STRENGTH OF 25 MPa.
  2. FORM FLOW THROUGH IN PARTIALLY SET CONCRETE & TROWEL SMOOTH.
  3. ALL JOINTS MORTARED INSIDE & OUT
  4. ALL DIMENSIONS GIVEN IN MILLIMETRES
  5. MAX. DISTANCE FROM RIM TO TOP RUNG IS 800mm
  6. BACKFILL WITH SELECT NATIVE MATERIAL
  7. DROP TO BE CONSTRUCTED FROM SAME MATERIALS AS PIPE
  8. ALL PRECAST MANHOLES MUST CONFORM TO A.S.T.M. SPECIFICATION C478

DATE: MARCH 1998	TITLE: <b>DROP MANHOLE DETAIL</b>	ACAD - CIVIL DRAFTING STANDARD DETAILS
TOWN OF VALLEYVIEW		FIGURE: <b>8</b>

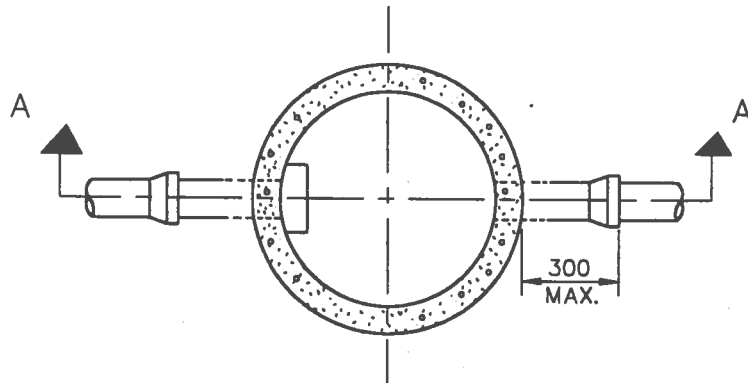
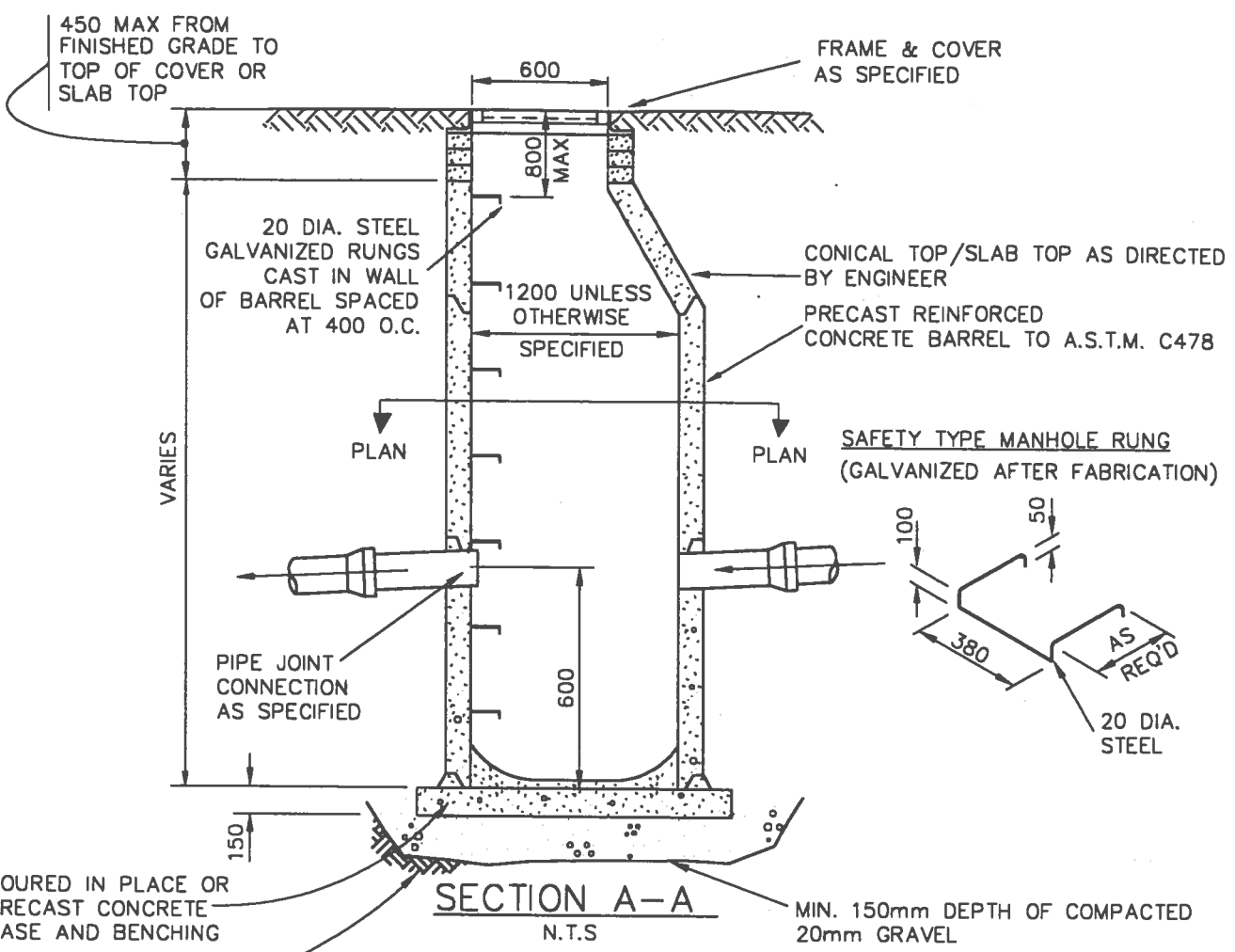

**NOTES:**

1. ALL PRECAST MANHOLES MUST CONFORM TO A.S.T.M. C478
2. POURED IN PLACE CONCRETE SHALL HAVE 28 DAYS COMPRESSIVE STRENGTH 25 MPa
3. ALL DIMENSIONS ARE IN MILLIMETRES.
4. MAX. DISTANCE FROM RIM TO TOP RUNG IS 800mm.
5. ALL PRECAST MANHOLES MUST CONFORM TO A.S.T.M. SPECIFICATIONS
6. ALL JOINTS MORTARED INSIDE AND OUT
7. ALL JOINTS MORTARED INSIDE AND OUT
8. BACKFILL MANHOLE WITH SELECT NATIVE MATERIAL

DATE: MARCH 1998	TITLE: <b>CATCH BASIN MANHOLE</b>	ACAD - CIVIL DRAFTING STANDARD DETAILS
TOWN OF VALLEYVIEW		FIGURE: 9

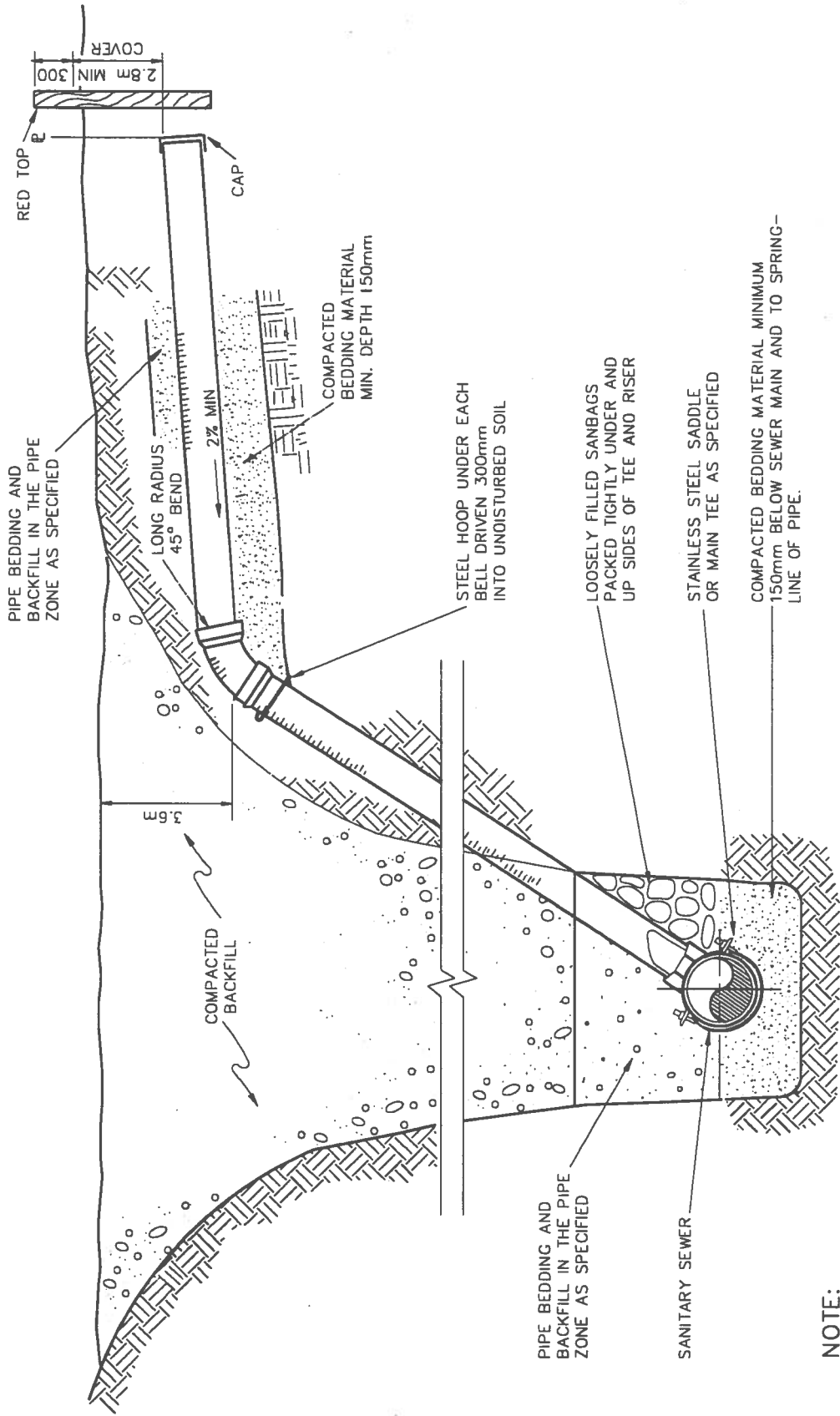

**NOTE:**

1. COMPACTION REQUIREMENTS AS PER DETAILED SPECIFICATIONS
2. ALL DIMENSIONS GIVEN IN MILLIMETRES
3. DEPTH OF COVER TO BE CONFIRMED BY THERMAL ANALYSIS.
4. RISER REQUIRED WHERE MAIN IS IN EXCESS OF 4.5m DEEP. RISERS SHALL BE INSTALLED TO WITHIN 3.6m OF FINISHED GRADE.

DATE: MARCH 1998

TOWN OF VALLEYVIEW

TITLE:

**SANITARY SEWER SERVICE CONNECTION RISER**

ACAD - CIVIL DRAFTING STANDARD DETAILS

FIGURE:

10

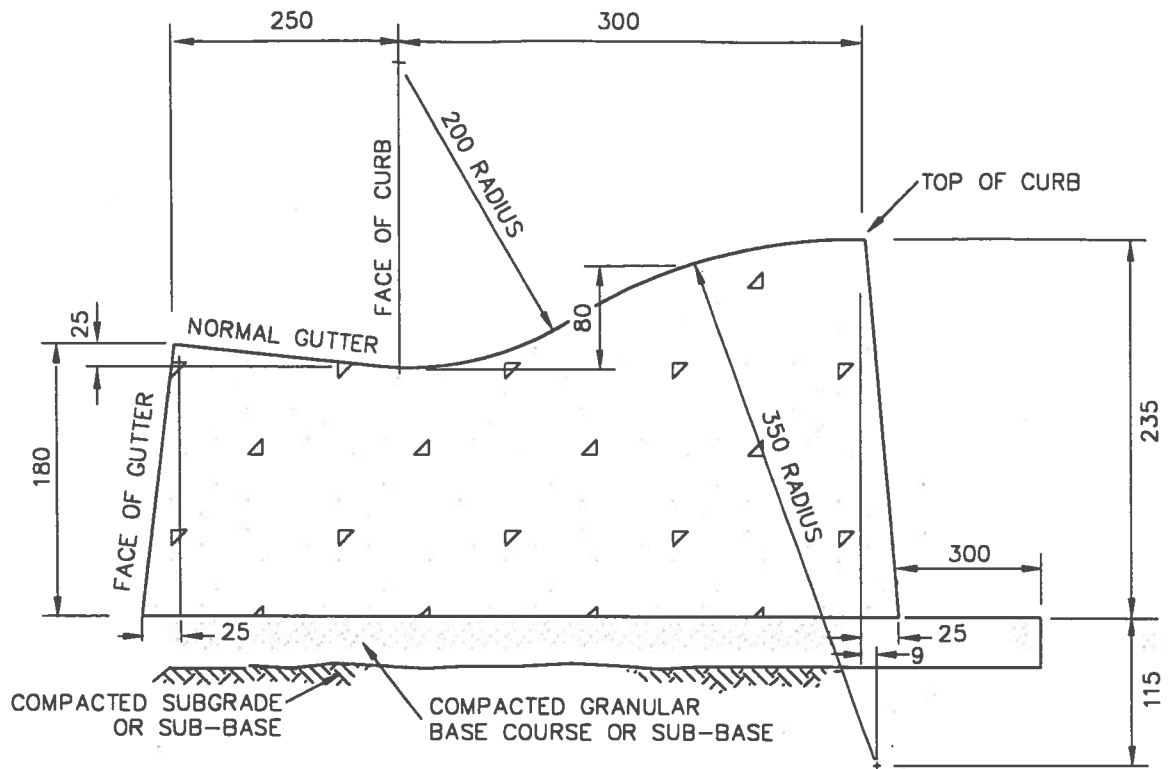

**TYPICAL ROLLED CURB & GUTTER**

N.T.S

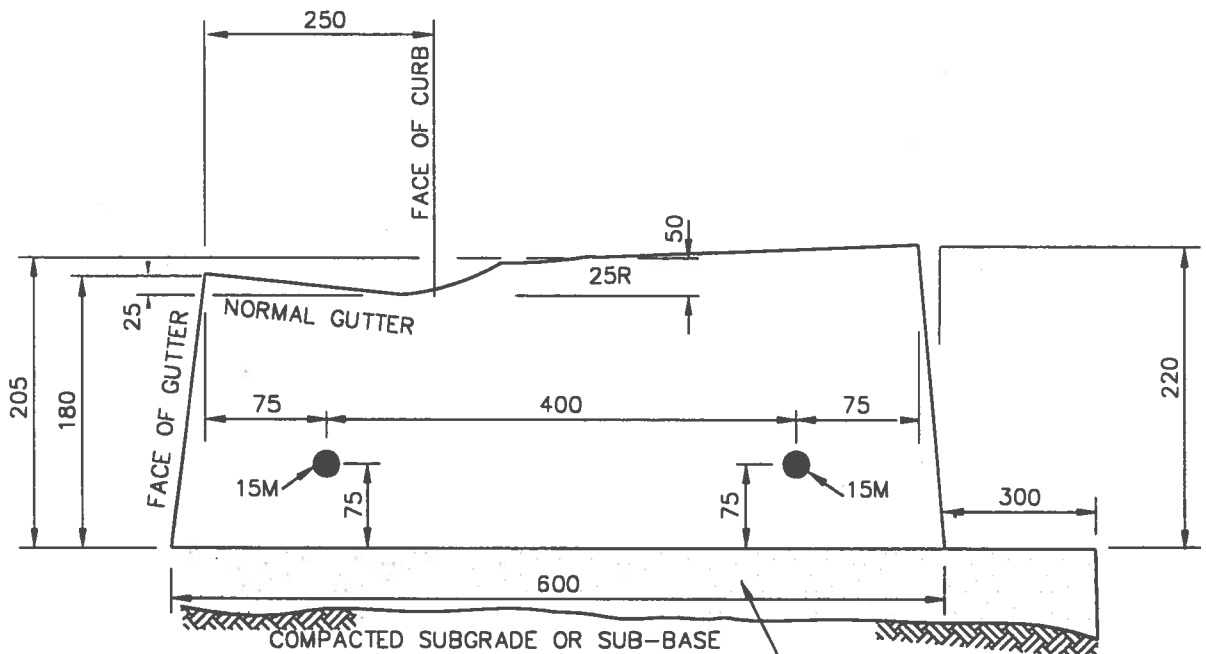

**CROSSING SECTION**

N.T.S

**NOTE**

1. ALL DIMENSIONS ARE IN MILLIMETRES
2. REINFORCEMENT NOT REQUIRED AT PRIVATE CROSSING

DATE: MARCH 1998	TITLE: <b>ROLLED CURB &amp; GUTTER AND CROSSING DETAILS COMMERCIAL, LANE AND PRIVATE</b>	ACAD - CIVIL DRAFTING STANDARD DETAILS
TOWN OF VALLEYVIEW		FIGURE: 11

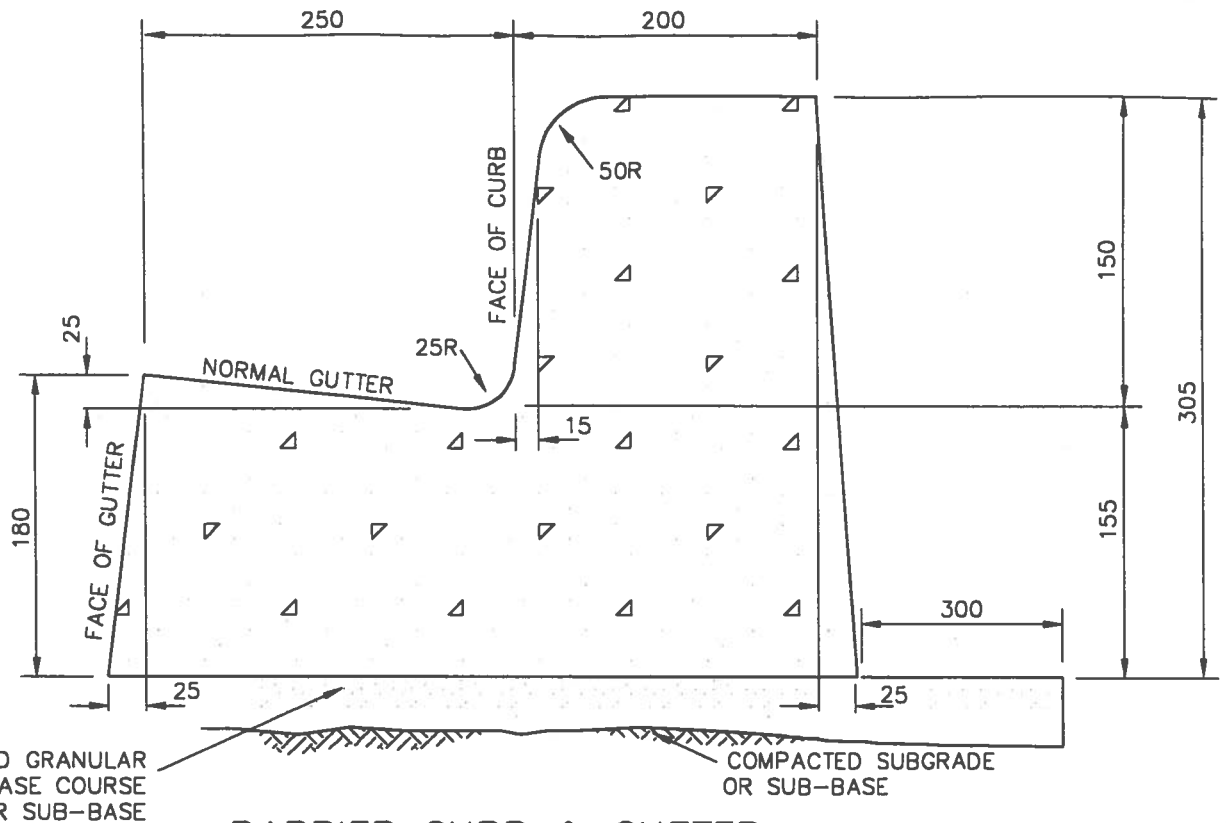

**BARRIER CURB & GUTTER**

N.T.S

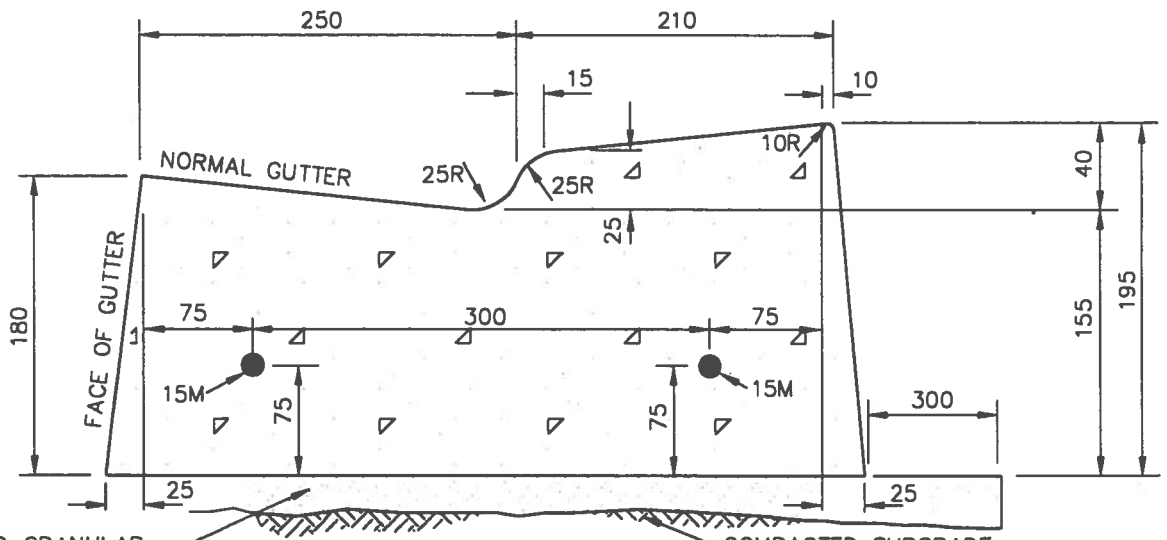

**CROSSING SECTION**

N.T.S

**NOTE:**

1. REINFORCEMENT NOT REQUIRED AT PRIVATE CROSSING
2. ALL DIMENSIONS ARE IN MILLIMETRES

DATE: MARCH 1998

TOWN OF VALLEYVIEW

TITLE:  
**150mm BARRIER CURB & GUTTER AND CROSSING DETAILS - COMMERCIAL, LANE AND PRIVATE**

ACAD - CIVIL DRAFTING STANDARD DETAILS

FIGURE:  
12

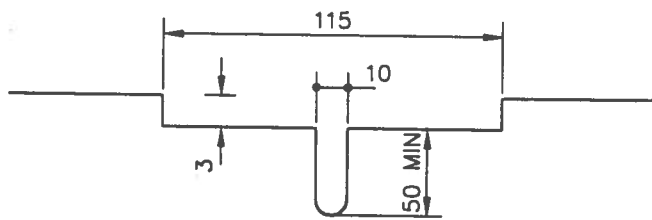
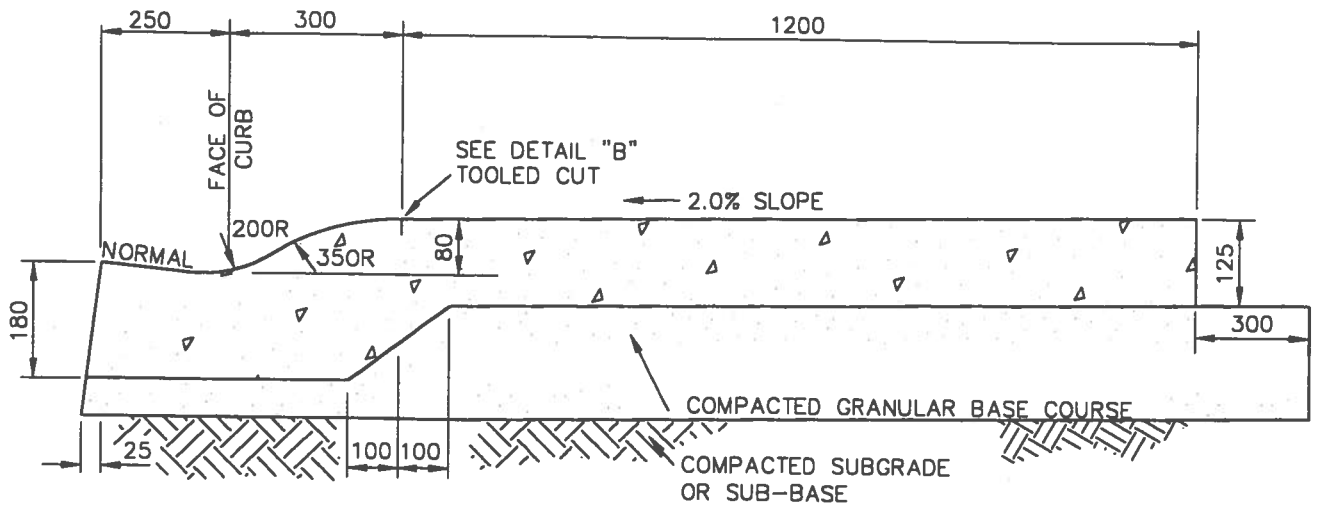

**NOTE:**

1. ALL DIMENSIONS ARE IN MILLIMETRES.

DATE: MARCH 1998

TOWN OF VALLEYVIEW

TITLE:

ROLLED MONOLITHIC CURB, GUTTER & SIDEWALK

ACAD - CIVIL DRAFTING STANDARD DETAILS

FIGURE:

13

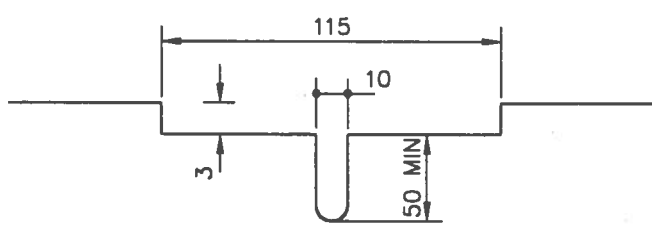
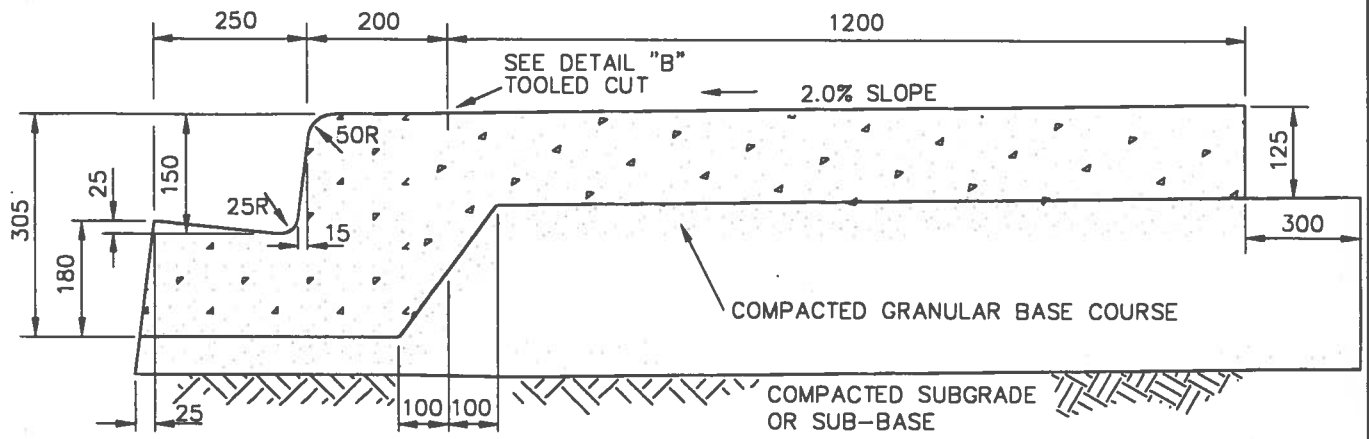

DETAIL "B"

**NOTE:**  
 1. ALL DIMENSIONS ARE IN MILLIMETRES.

DATE: MARCH 1998	TITLE: 150mm BARRIER MONOLITHIC CURB, GUTTER & SIDEWALK	ACAD - CIVIL DRAFTING STANDARD DETAILS
TOWN OF VALLEYVIEW		FIGURE: 14



**NOTE:**

1. MAINTAIN THICKENED DEPTH THROUGHOUT
2. ALL DIMENSIONS ARE IN MILLIMETRES
3. REINFORCEMENT AND THICKENING NOT REQUIRED AT PRIVATE CROSSING.
4. MINIMUM DEPTH OF CROSSING TO BE 1.4m IF PLACED WITHOUT SIDEWALK.

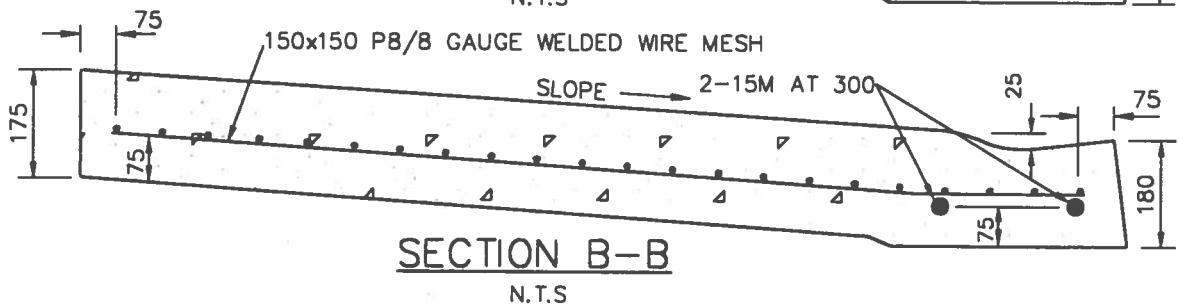
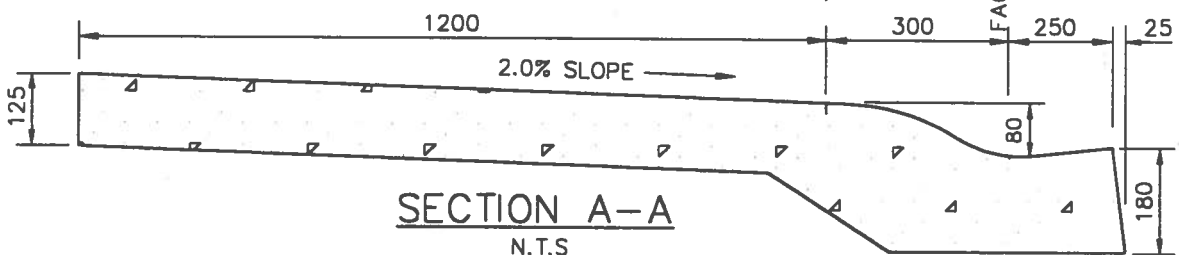
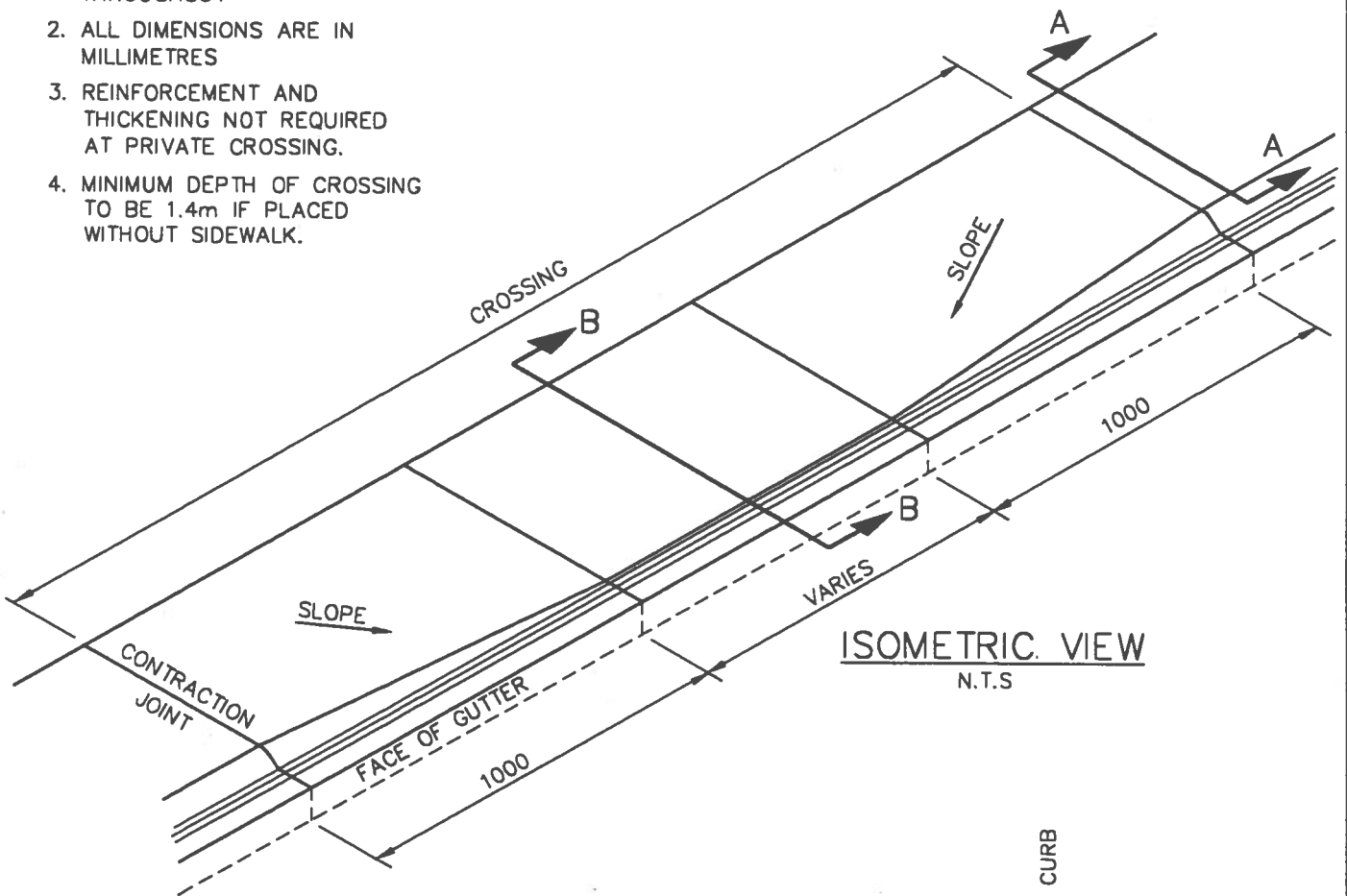

DATE: MARCH 1998  
TOWN OF VALLEYVIEW

TITLE: ROLLED MONOLITHIC CROSSING DETAILS COMMERCIAL, LANE AND PRIVATE

ACAD - CIVIL DRAFTING STANDARD DETAILS  
FIGURE: 15

**NOTE:**

1. MAINTAIN THICKENED DEPTH THROUGHOUT.
2. ALL DIMENSIONS ARE IN MILLIMETRES
3. DROP BACK OF CROSSING 50mm FOR WIDTH OF CROSSING
4. REINFORCING AND THICKENING NOT REQUIRED AT PRIVATE CROSSINGS.
5. MIN. DEPTH OF CROSSING TO BE 1.4m IF PLACED WITHOUT SIDEWALK.

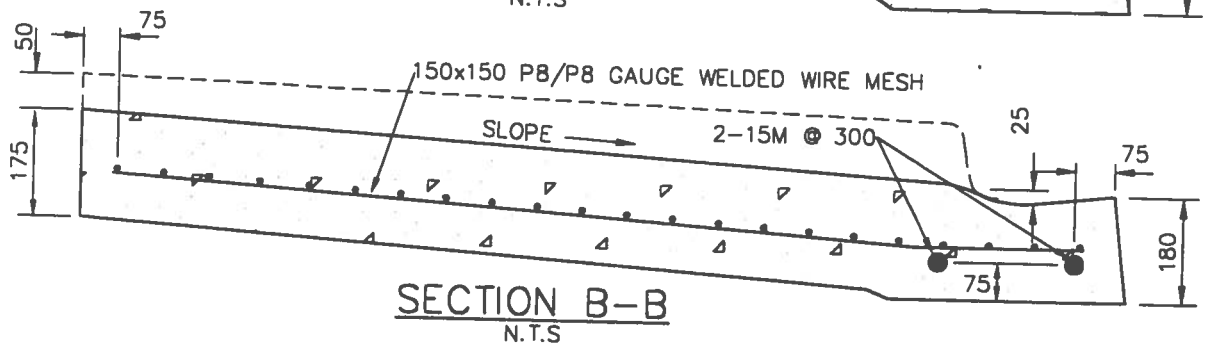
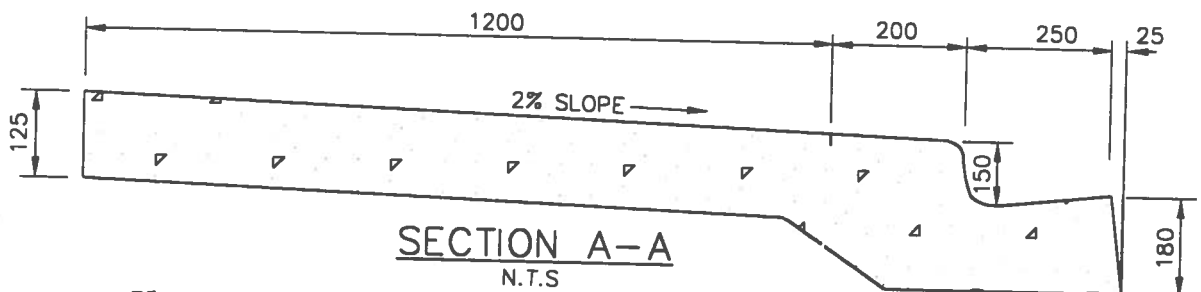
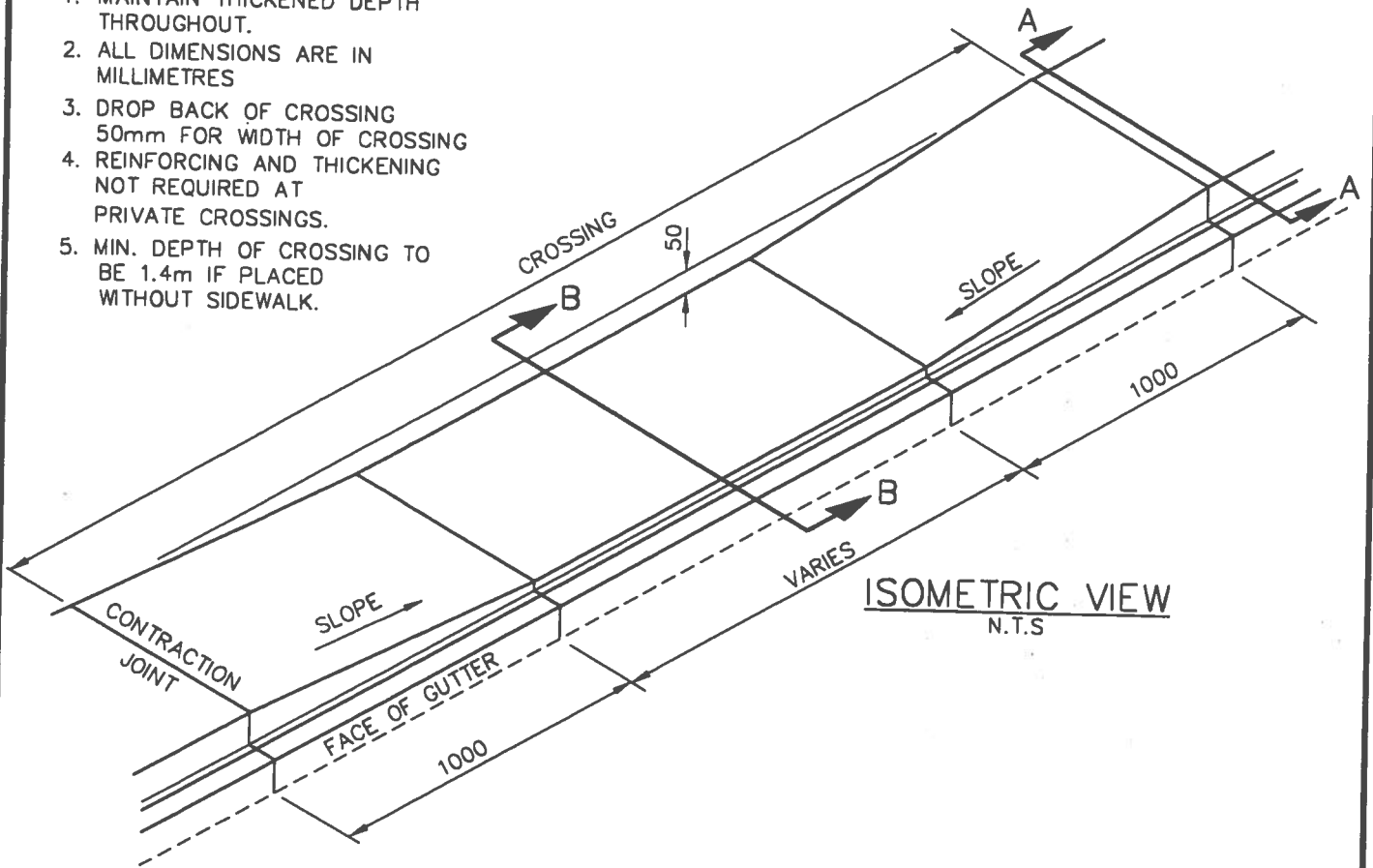

DATE: MARCH 1998	TITLE: 150mm BARRIER MONOLITHIC CROSSING DETAILS COMMERCIAL, LANE & PRIVATE CROSSINGS	ACAD - CIVIL DRAFTING STANDARD DETAILS
TOWN OF VALLEYVIEW		FIGURE:
		16

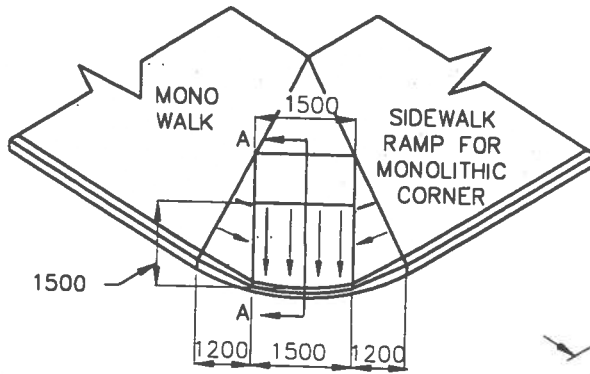

TYPE A  
N.T.S.

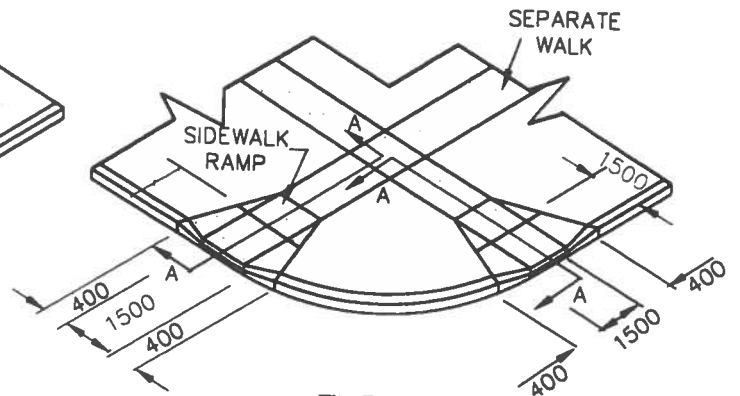

TYPE B  
N.T.S.

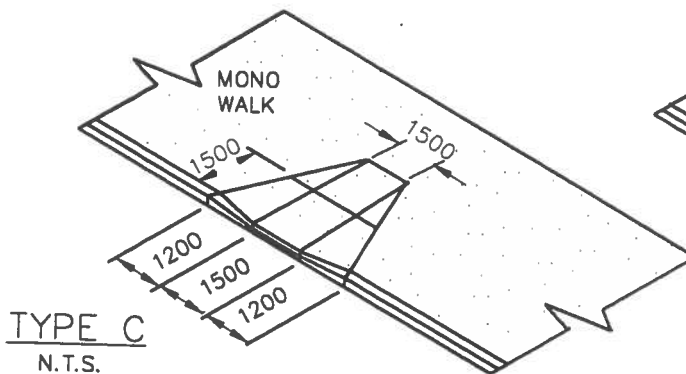

TYPE C  
N.T.S.

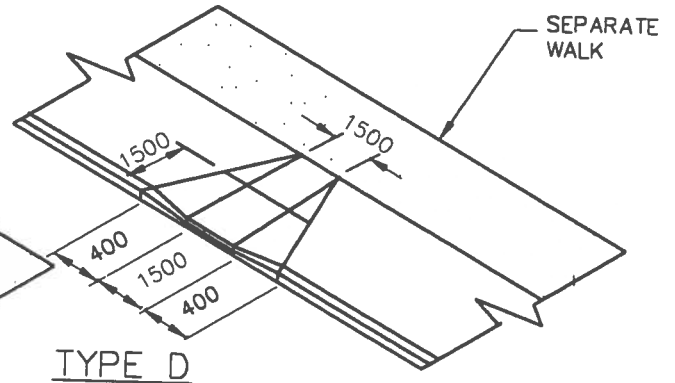

TYPE D  
N.T.S.

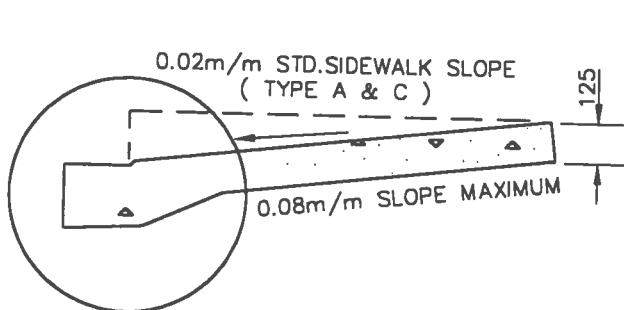

SCALE: HOR. 1:25  
VERT. 1:20

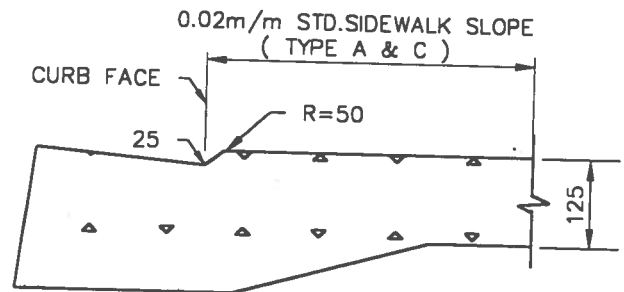

SCALE: HOR. 1:10  
VERT. 1:10

**NOTES:**

1. WHERE RAMP IS TO BE USED AS A TRANSITION. USE THE CENTRE OF THE 1500mm RAMP AS THE CENTRE OF THE TRANSITION.
2. WHERE CURB FACE IS 200mm. DISTANCE OF FLARE SHOULD BE 1600mm.
3. CURBS AND RAMPS TO BE POURED MONOLITHICALLY.
4. CONSTRUCTION JOINT REQUIRED AT EACH SIDE OF RAMP.
5. ALL DIMENSIONS IN MILLIMETRES UNLESS OTHERWISE NOTED

DATE: MARCH 1998	TITLE: <b>WHEEL CHAIR/BIKE RAMP DETAILS</b>	ACAD - CIVIL DRAFTING STANDARD DETAILS
TOWN OF VALLEYVIEW		FIGURE: 17

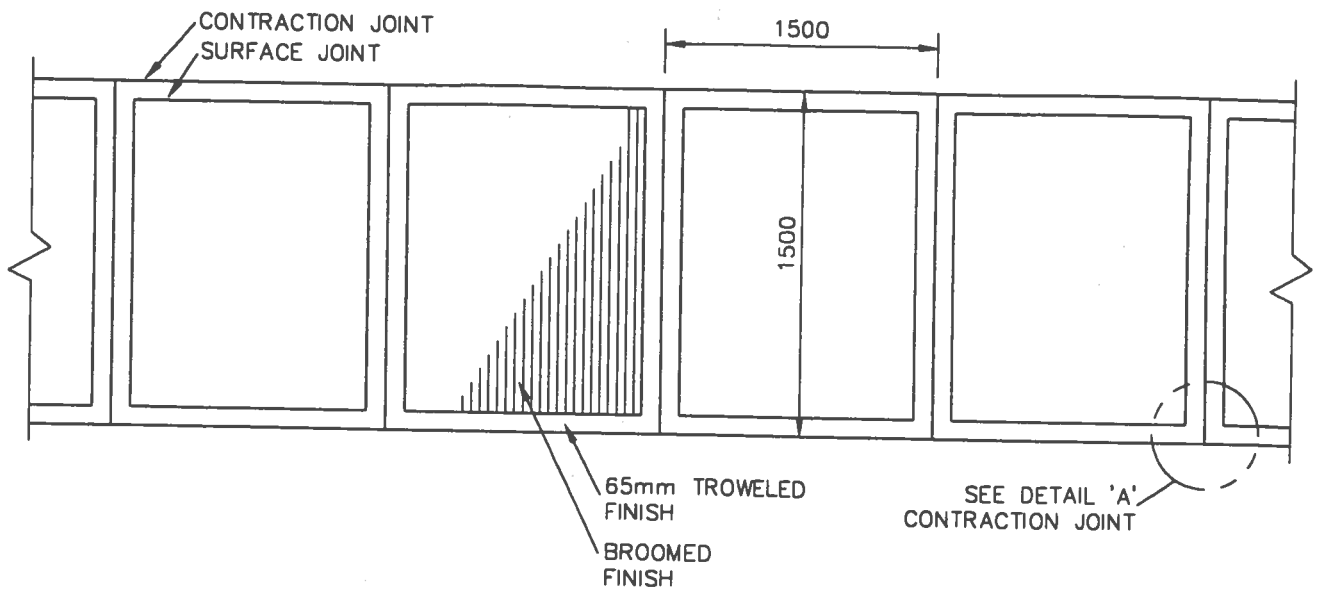

PLAN  
N.T.S

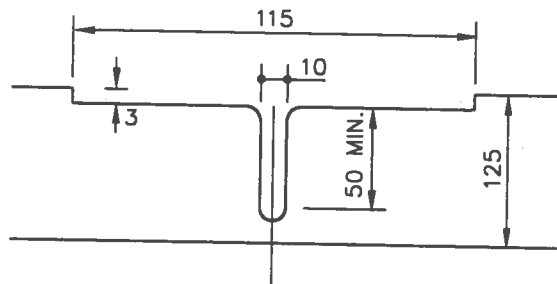

DETAIL 'A'  
N.T.S

NOTES:

1. SIDEWALK CROSS-FALL TO BE 2% TOWARDS TOP OF CURB.
2. EXPANSION MATERIAL SHALL BE PLACED WHEN ABUTTING EXISTING STRUCTURES.
3. SIDEWALK SHALL HAVE A "BROOMED" FINISH.
4. TRANSVERSE CONTRACTION JOINTS AT THE END OF EACH POUR, AND AT 3m INT.
5. TRANSVERSE SURFACE JOINTS EVERY 3 METRES MIDWAY BETWEEN CONTRACTION JOINTS.
6. ALL DIMENSIONS ARE GIVEN IN MILLIMETRES.

DATE: MARCH 1998	TITLE: <b>SEPARATE SIDEWALK DETAILS</b>	ACAD - CIVIL DRAFTING STANDARD DETAILS
TOWN OF VALLEYVIEW		FIGURE: 18

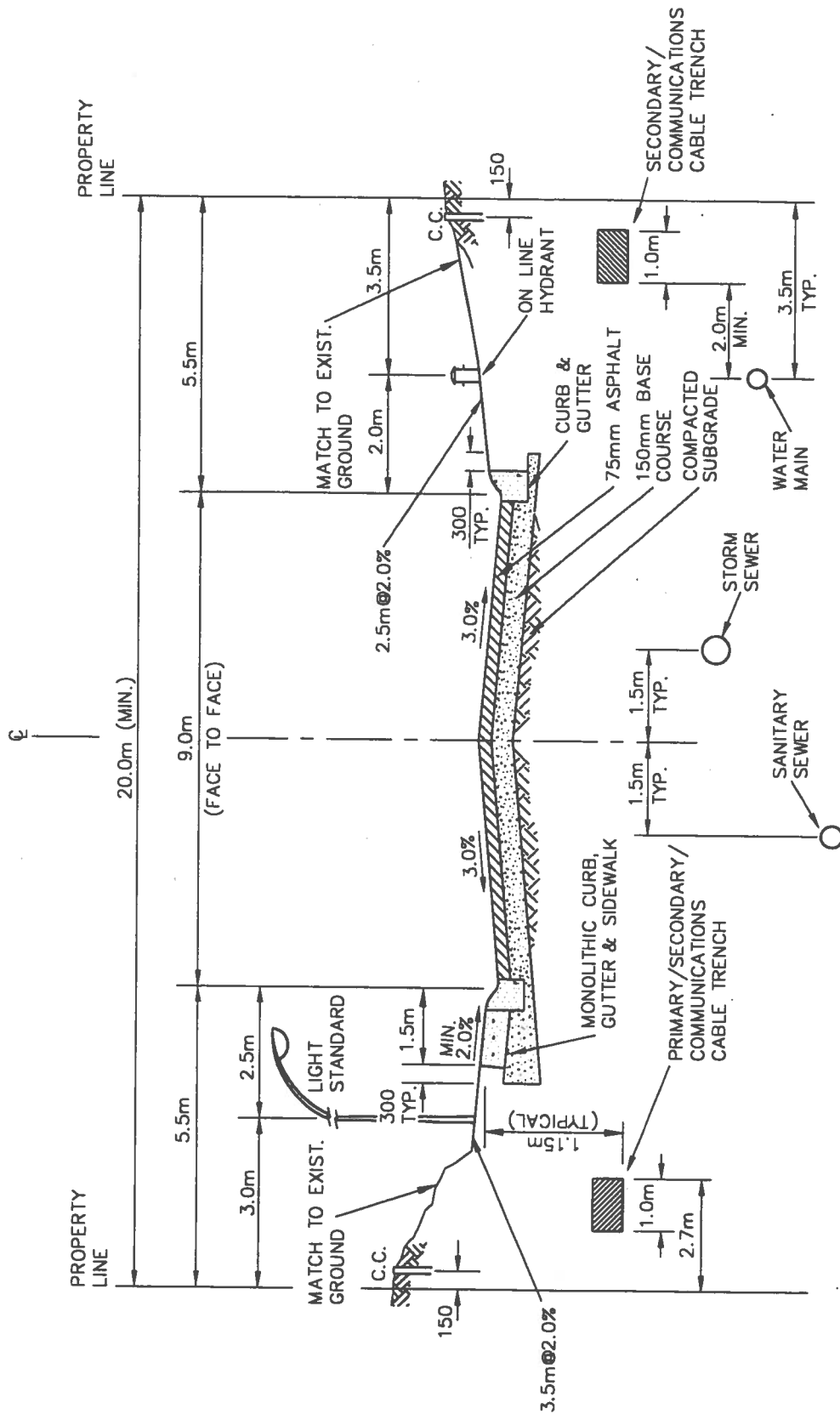

SECTION  
N.T.S

NOTES:

1. ALL DIMENSIONS ARE IN MILLIMETRES UNLESS OTHERWISE NOTED.
2. MINIMUM ROAD STRUCTURE, ROADWAY TO BE DESIGNED BASED ON SITE SPECIFIC SOIL CONDITIONS AND TRAFFIC LOADINGS.
3. MINIMUM CUL-DE-SAC RADIUS 11.0m.
4. RTAC CLASSIFICATION ULU-50.

DATE: MARCH 1998

TITLE:

9.0m RESIDENTIAL  
STREET SECTION  
WITH MONO SIDEWALK

ACAD - CIVIL DRAFTING  
STANDARD DETAILS

TOWN  
OF  
VALLEYVIEW

FIGURE:

19

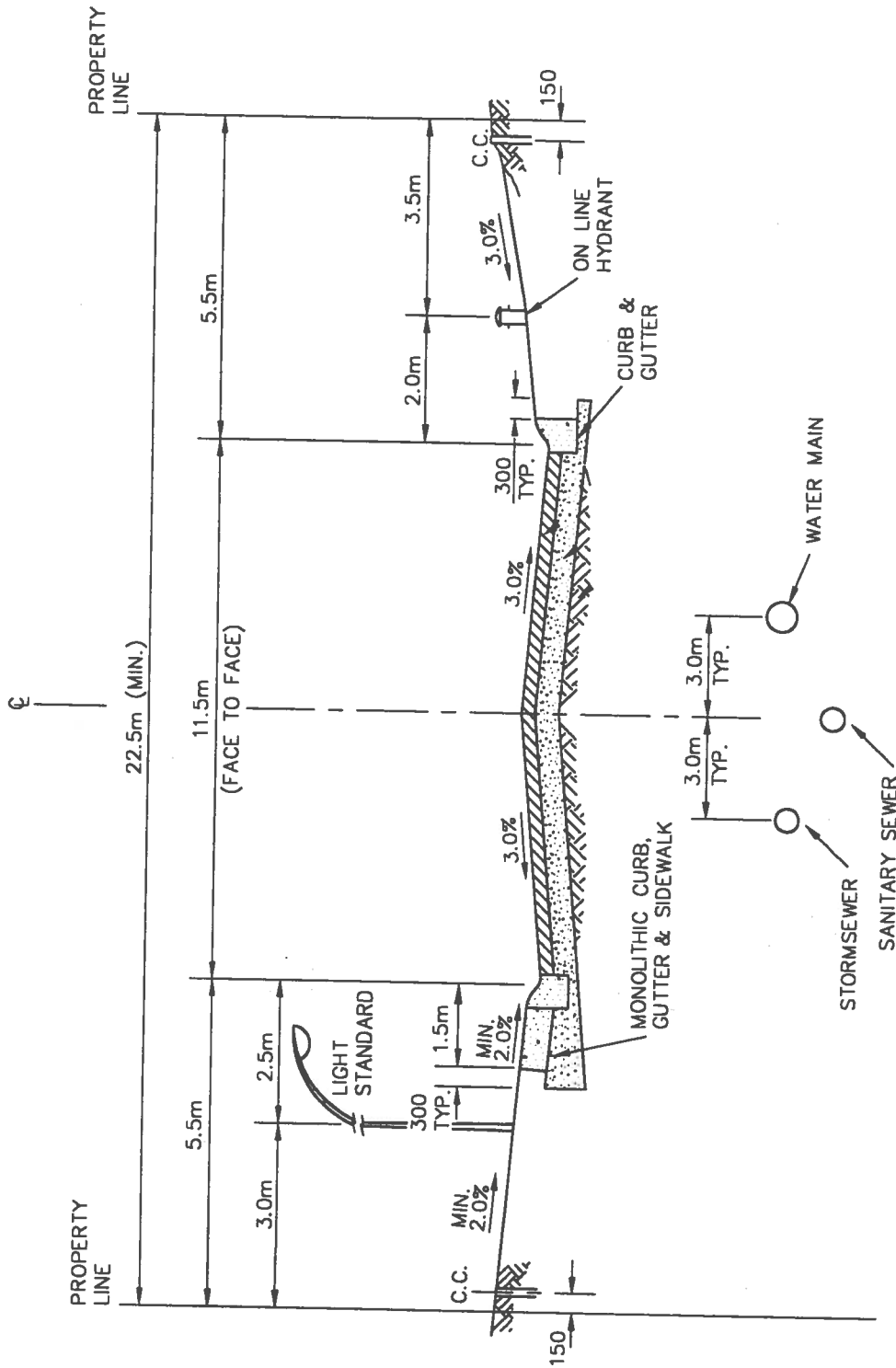

SECTION  
N.T.S

NOTES:

1. ALL DIMENSIONS ARE IN MILLIMETRES UNLESS OTHERWISE NOTED.
2. MINIMUM ROAD STRUCTURE. ROADWAY TO BE DESIGNED BASED ON SITE SPECIFIC SOIL CONDITIONS AND TRAFFIC LOADINGS.
3. MINIMUM CUL-DE-SAC RADIUS 14.0m.
4. RTAC CLASSIFICATION UCU-50.

DATE: MARCH 1998

TOWN OF VALLEYVIEW

TITLE:  
11.5m URBAN MINOR COLLECTOR STREET SECTION WITH MONO SIDEWALK

ACAD - CIVIL DRAFTING STANDARD DETAILS

FIGURE:

20

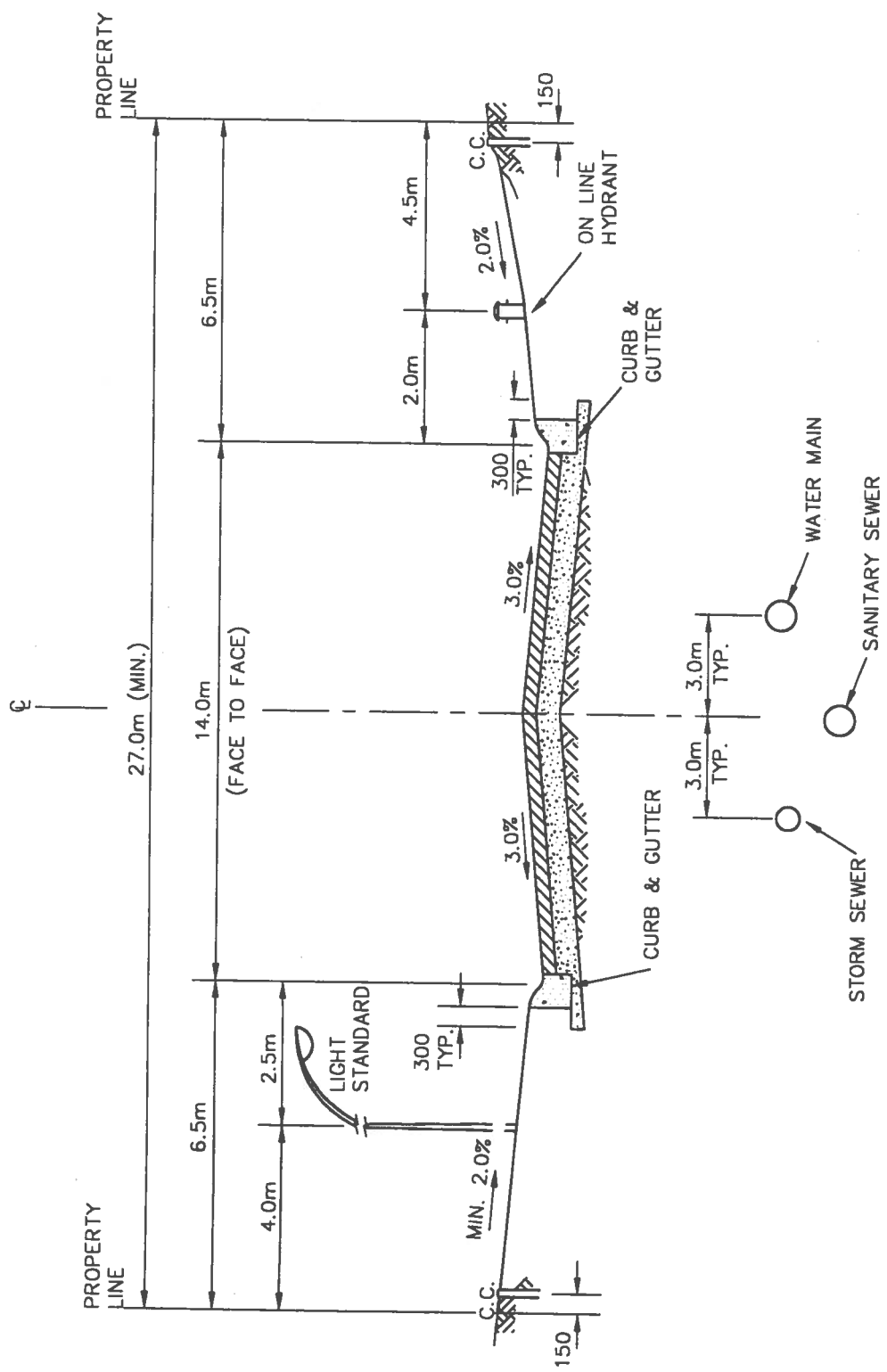

**SECTION**  
N.T.S

- NOTES:**
1. ALL DIMENSIONS ARE IN MILLIMETRES UNLESS OTHERWISE NOTED.
  2. MINIMUM ROAD STRUCTURE. ROADWAY TO BE DESIGNED BASED ON SITE SPECIFIC SOIL CONDITIONS AND TRAFFIC LOADINGS.
  3. MINIMUM CUL-DE-SAC RADIUS 14.0m.
  4. RTAC CLASSIFICATION UCU-60.

DATE: MARCH 1998

TOWN OF VALLEYVIEW

TITLE: 14.0m URBAN MAJOR COLLECTOR STREET SECTION WITH SEPERATE SIDEWALK

ACAD - CIVIL DRAFTING STANDARD DETAILS

FIGURE: 21

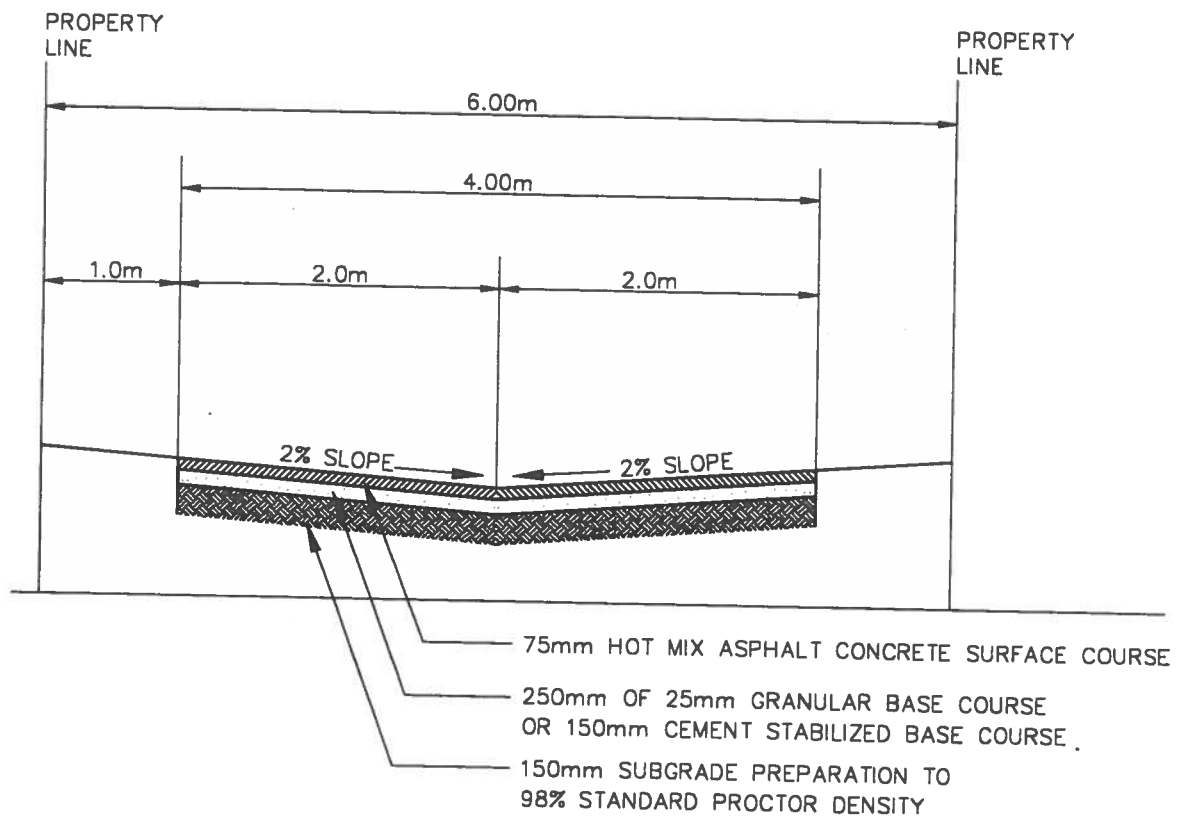

**NOTES:**

1. MINIMUM ROAD STRUCTURE. ROADWAY TO BE DESIGNED BASED ON SITE SPECIFIC SOIL CONDITIONS AND TRAFFIC LOADINGS.
2. ALL DIMENSIONS ARE IN MILLIMETRES UNLESS OTHERWISE NOTED.
3. EDGE OF PAVEMENT TO BE WARPED TO FIT DRIVEWAYS.

DATE: MARCH 1998	TITLE:  4.0m PAVED RESIDENTIAL LANE	ACAD – CIVIL DRAFTING STANDARD DETAILS
TOWN OF VALLEYVIEW		FIGURE: 22



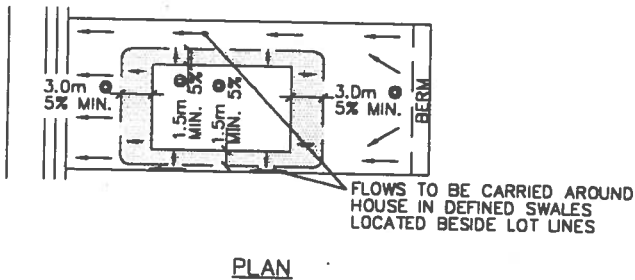
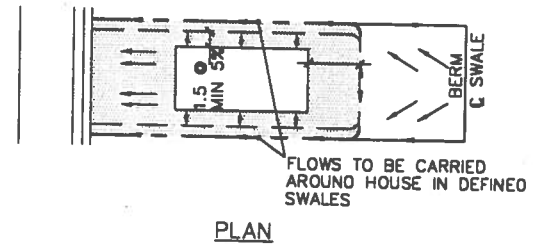
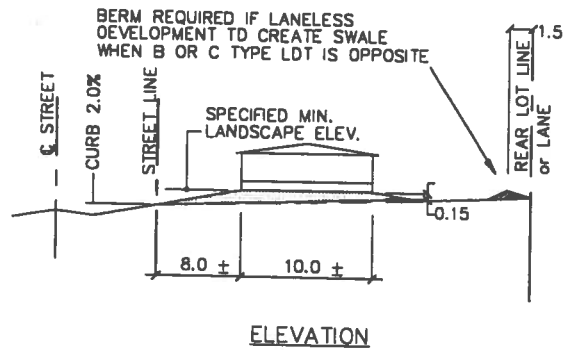
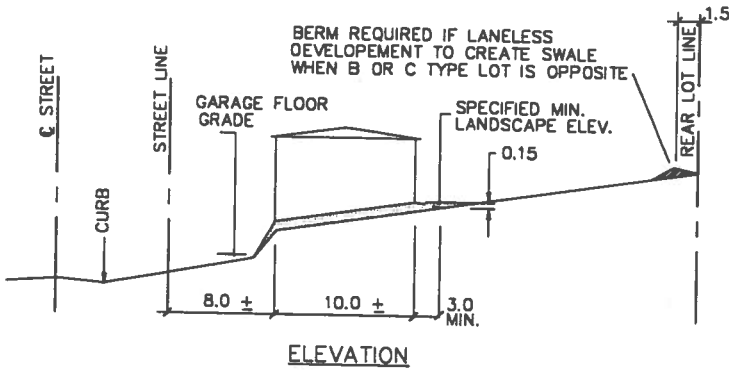
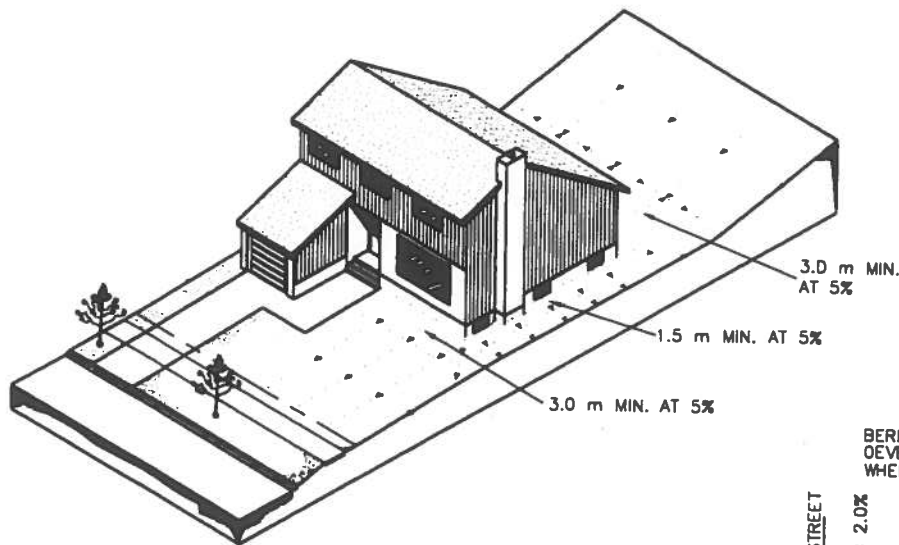

**CONVENTIONAL AND SPLIT BUNGALOW HOUSE TYPE**

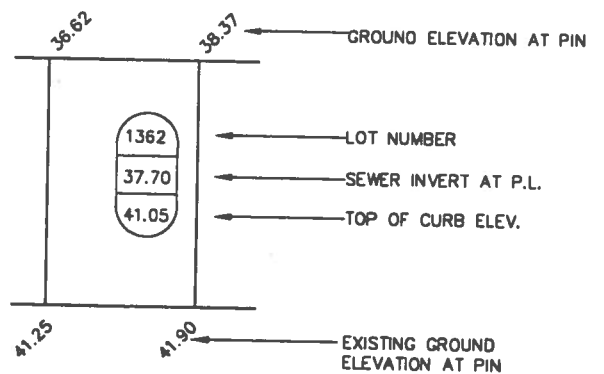

**BASEMENT GARAGE AND FRONT WALKOUT HOUSE TYPE**

**NOTE:**

1. FINISH LANDSCAPE ELEVATION ADJACENT TO HOUSE TO BE 0.15m ABOVE EXISTING GROUND
2. ALL DIMENSIONS IN METRES UNLESS NOTED OTHERWISE.

DATE:  
MARCH 1998

TOWN OF  
VALLEYVIEW

TITLE:  
**TYPICAL FRONT LOT DRAINAGE TYPE A**

ACAD - CIVIL DRAFTING STANDARD DETAILS

FIGURE:  
23

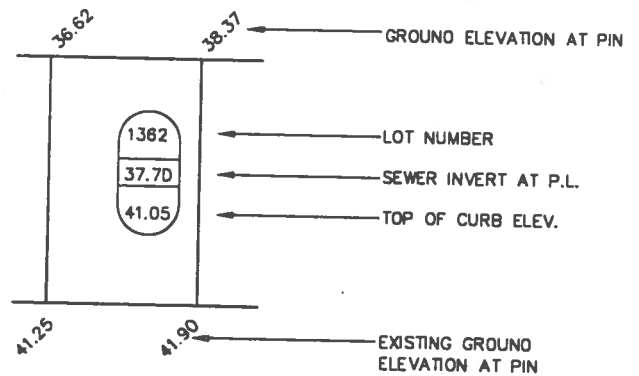
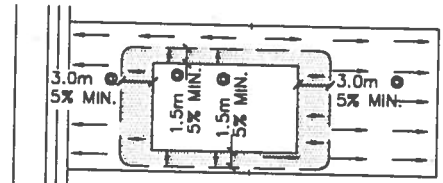
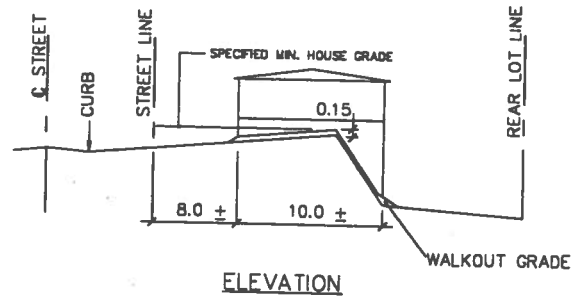
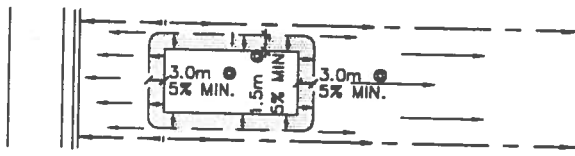
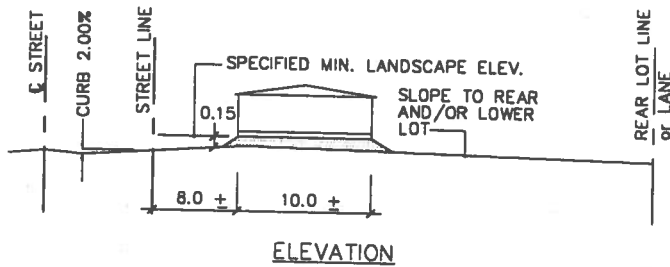
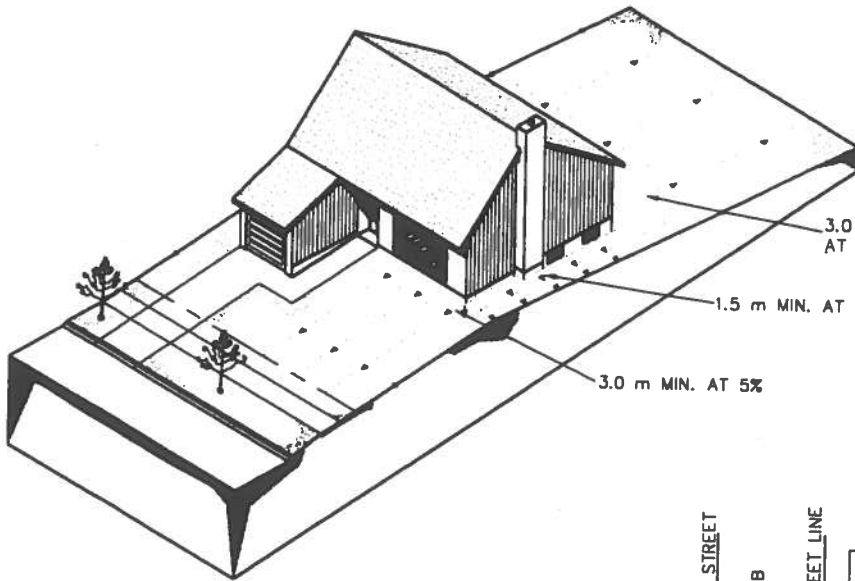

**NOTE:**

1. FINISH LANDSCAPE ELEVATION ADJACENT TO HOUSE TO BE 0.15m ABOVE EXISTING GROUND
2. ALL DIMENSIONS IN METRES UNLESS NOTED OTHERWISE.

DATE: MARCH 1998	TITLE: <b>TYPICAL SPLIT LOT DRAINAGE TYPE B</b>	ACAD – CIVIL DRAFTING STANDARD DETAILS
TOWN OF VALLEYVIEW		FIGURE: 24

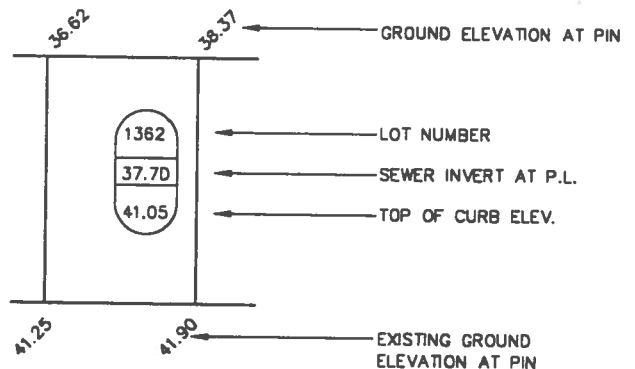
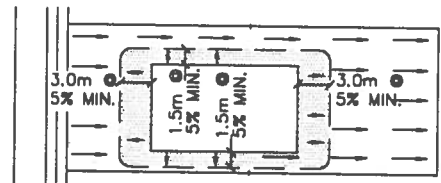
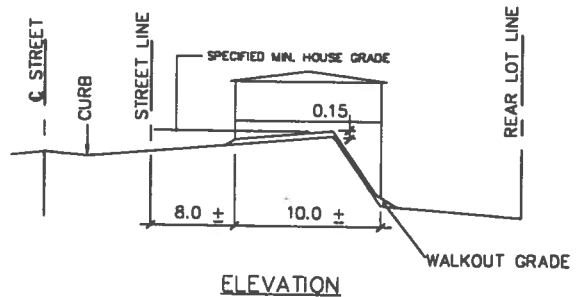
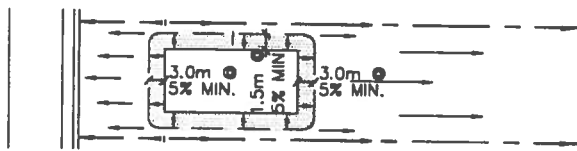
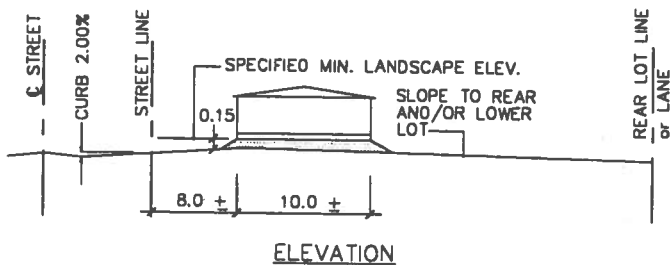
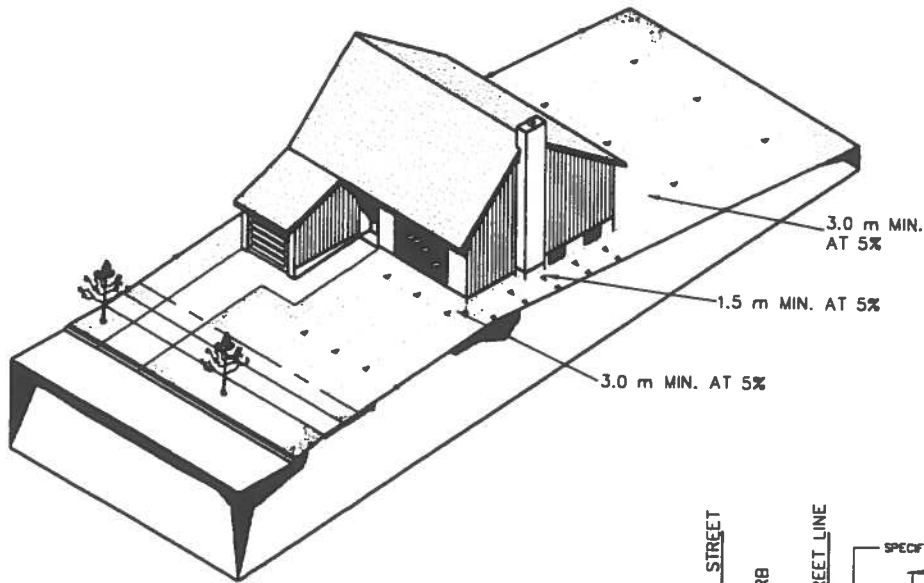

**NOTE:**

1. FINISH LANDSCAPE ELEVATION ADJACENT TO HOUSE TO BE 0.15m ABOVE EXISTING GROUND
2. ALL DIMENSIONS IN METRES UNLESS NOTED OTHERWISE.

DATE: MARCH 1998	TITLE: <b>TYPICAL REAR LOT DRAINAGE TYPE C</b>	ACAD - CIVIL DRAFTING STANDARD DETAILS
TOWN OF VALLEYVIEW		FIGURE: 25

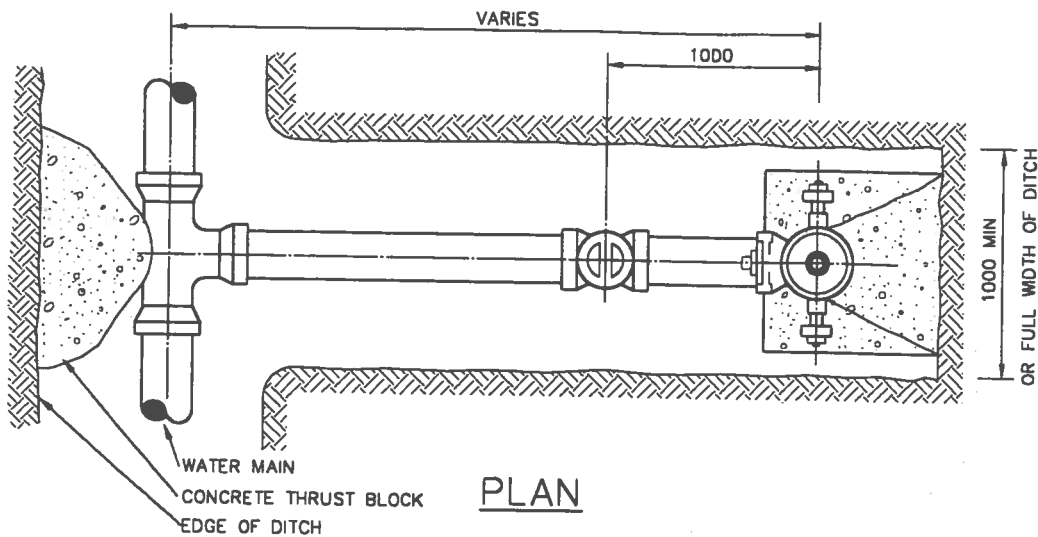

**PLAN**

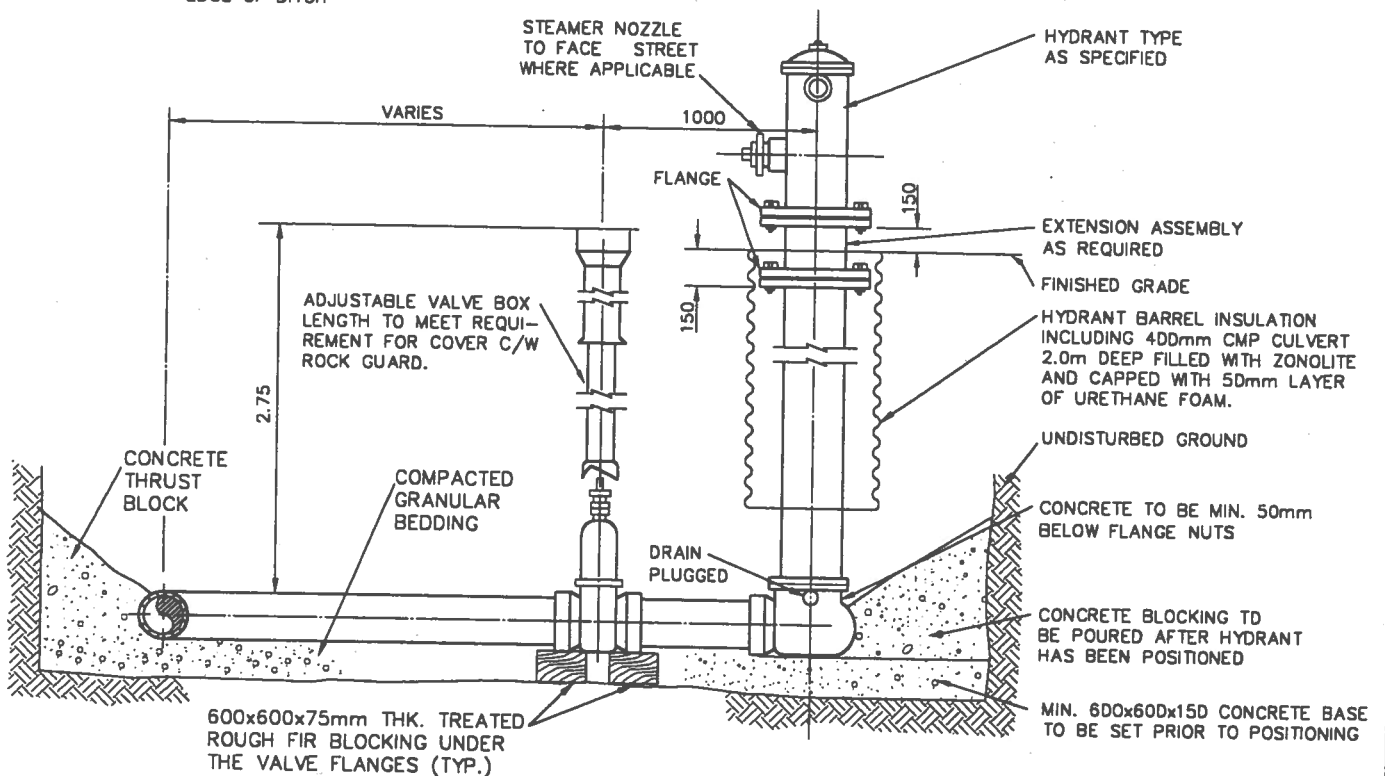

**ELEVATION**

**NOTES:**

1. ALL DIMENSIONS ARE IN MILLIMETRES.
2. ALL FITTINGS TO BE WRAPPED IN POLY PRIOR TO POURING CONCRETE.
3. CONCRETE TO BE 20 MPa @ 28 DAYS.
4. HYDRANTS SHALL BE COMPRESSION TYPE CONFORMING TO AWWA C502 COMPLETE WITH UNPLUGGED DRAINS, STAINLESS STEEL BOLTS AND ASPHALTIC COATED BURIED HYDRANT COMPONENTS.
5. PLUG HYDRANT DRAIN HOLES IF GROUND WATER LEVEL IS HIGHER THAN HYDRANT BOTTOM FLANGE. MARK HYDRANT BARREL WITH THE WORDS "NO DRAIN" PAINTED IN WHITE LETTERS 50mm HIGH.

DATE: MARCH 1998	TITLE: <b>OFF-LINE HYDRANT DETAIL</b>	ACAD - CIVIL DRAFTING STANDARD DETAILS
TOWN OF VALLEYVIEW		FIGURE: 26

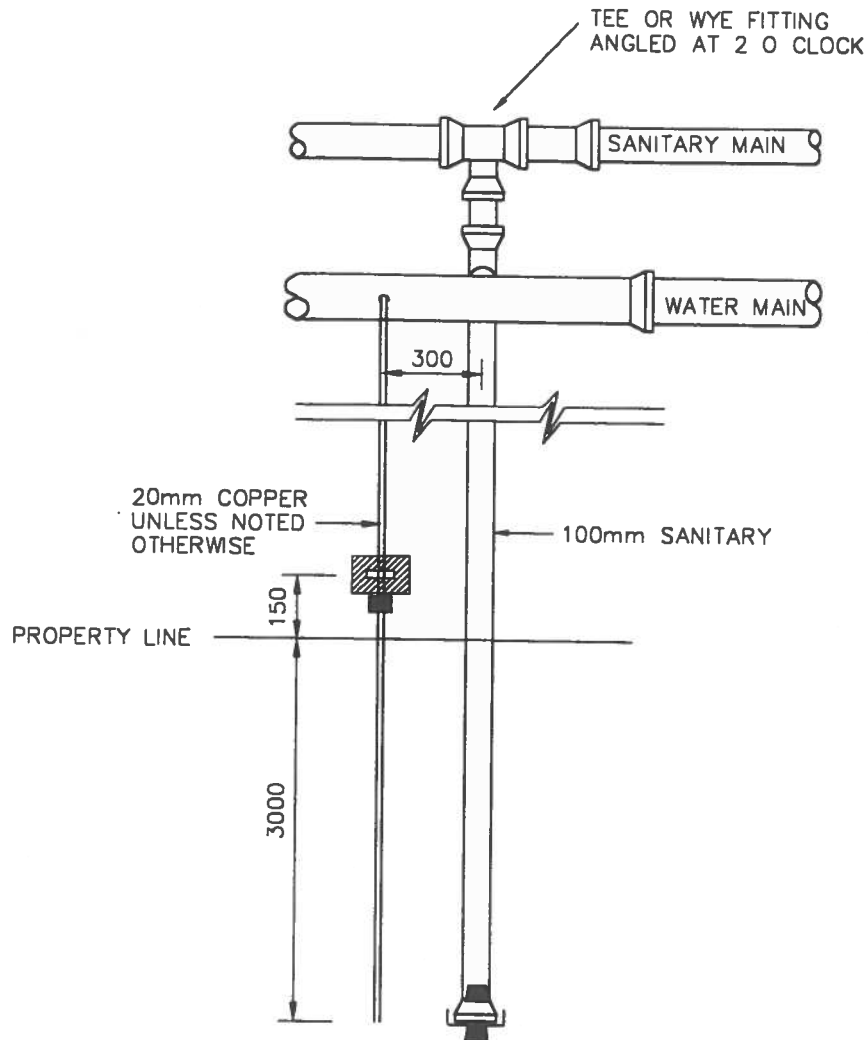

**NOTE:**

1. MUNICIPALITY IS NOT RESPONSIBLE FOR OWNERSHIP OR MAINTENANCE OF SERVICE ON PRIVATE PROPERTY.
2. ENDS OF SERVICES TO BE MARKED WITH A 38mm x 90mm STAKE PROTRUING 300mm ABOVE GROUND PAINTED AS FOLLOWS:
  - A. CURBSTOP - BLUE
  - B. END OF SERVICE IN SEPERATE TRENCH - GREEN
  - C. END OF WATER SERVICE INSIDE PRIVATE PROPERTY - BLUE
3. ENDS OF ANY WATER SERVICE EXTENDED INTO PRIVATE PROPERTY TO HAVE FILTER CLOTH OR APPROVE EQUIVALENT TAPED ON END TO ALLOW TESTING OF CURBSTOP.
4. SEWER SERVICES MUST BE PROPERLY CAPPED
5. ALL DIMENSIONS GIVEN IN MILLIMETRES.

DATE: MARCH 1998	TITLE:  SINGLE SERVICE LAYOUT (NEW INSTALLATION)	ACAD - CIVIL DRAFTING STANDARD DETAILS
TOWN OF VALLEYVIEW		FIGURE:  27